

ドラッグコスモス籠原店新設計画に伴う

交通計画書

現況交通量調査の実施

■調査実施日・時間帯

令和7年10月26日（日） 8時～23時 天候 曇り
令和7年10月27日（月） 8時～23時 天候 曇り

■調査項目

●交通量調査

計画地周辺交差点5交差点にて、1時間毎に2車種にわけて各方向別に観測記録した。
車種分類については、大型車両、小型車両の2分類とした。

●信号青時間調査

信号周期及び各現示点灯時間を観測記録した。

■調査地点

調査地点は下図に示す通りである。



○：交通量調査地点

地点	No.1																																																																																																																																																																																																																																																																																																																																	
調査日	令和7年10月26日(日)																																																																																																																																																																																																																																																																																																																																	
天候	曇り																																																																																																																																																																																																																																																																																																																																	
概要	当交差点の交通量ピークは13時～14時であった。																																																																																																																																																																																																																																																																																																																																	
調査方向区分	AからDへ右折 方向1			AからCへ直進 方向2			AからBへ左折 方向3			BからAへ右折 方向4			BからDへ直進 方向5			BからCへ左折 方向6																																																																																																																																																																																																																																																																																																																		
車両区分	大型車	小型車	合計	大型車	小型車	合計	大型車	小型車	合計	大型車	小型車	合計	大型車	小型車	合計	大型車	小型車	合計																																																																																																																																																																																																																																																																																																																
時刻	<table border="1"> <tr><td>8時～9時</td><td>4</td><td>149</td><td>153</td><td>0</td><td>0</td><td>0</td><td>1</td><td>7</td><td>8</td><td>0</td><td>0</td><td>0</td><td>1</td><td>255</td><td>256</td><td>0</td><td>0</td><td>0</td></tr> <tr><td>9時～10時</td><td>4</td><td>166</td><td>170</td><td>0</td><td>0</td><td>0</td><td>2</td><td>9</td><td>11</td><td>0</td><td>0</td><td>0</td><td>1</td><td>289</td><td>290</td><td>0</td><td>0</td><td>0</td></tr> <tr><td>10時～11時</td><td>5</td><td>181</td><td>186</td><td>0</td><td>0</td><td>0</td><td>2</td><td>13</td><td>15</td><td>0</td><td>0</td><td>0</td><td>2</td><td>328</td><td>330</td><td>0</td><td>0</td><td>0</td></tr> <tr><td>11時～12時</td><td>3</td><td>188</td><td>191</td><td>0</td><td>0</td><td>0</td><td>1</td><td>18</td><td>19</td><td>0</td><td>0</td><td>0</td><td>2</td><td>384</td><td>386</td><td>0</td><td>0</td><td>0</td></tr> <tr><td>12時～13時</td><td>8</td><td>193</td><td>201</td><td>0</td><td>0</td><td>0</td><td>0</td><td>13</td><td>13</td><td>0</td><td>0</td><td>0</td><td>1</td><td>443</td><td>444</td><td>0</td><td>0</td><td>0</td></tr> <tr><td>13時～14時</td><td>10</td><td>211</td><td>221</td><td>0</td><td>0</td><td>0</td><td>1</td><td>11</td><td>12</td><td>0</td><td>0</td><td>0</td><td>2</td><td>504</td><td>506</td><td>0</td><td>0</td><td>0</td></tr> <tr><td>14時～15時</td><td>6</td><td>199</td><td>205</td><td>0</td><td>0</td><td>0</td><td>0</td><td>7</td><td>7</td><td>0</td><td>0</td><td>0</td><td>5</td><td>387</td><td>392</td><td>0</td><td>0</td><td>0</td></tr> <tr><td>15時～16時</td><td>8</td><td>144</td><td>152</td><td>0</td><td>0</td><td>0</td><td>2</td><td>10</td><td>12</td><td>0</td><td>0</td><td>0</td><td>2</td><td>406</td><td>408</td><td>0</td><td>0</td><td>0</td></tr> <tr><td>16時～17時</td><td>8</td><td>216</td><td>224</td><td>0</td><td>0</td><td>0</td><td>1</td><td>12</td><td>13</td><td>0</td><td>0</td><td>0</td><td>3</td><td>380</td><td>383</td><td>0</td><td>0</td><td>0</td></tr> <tr><td>17時～18時</td><td>7</td><td>209</td><td>216</td><td>0</td><td>0</td><td>0</td><td>3</td><td>19</td><td>22</td><td>0</td><td>0</td><td>0</td><td>1</td><td>377</td><td>378</td><td>0</td><td>0</td><td>0</td></tr> <tr><td>18時～19時</td><td>6</td><td>178</td><td>184</td><td>0</td><td>0</td><td>0</td><td>2</td><td>13</td><td>15</td><td>0</td><td>0</td><td>0</td><td>2</td><td>354</td><td>356</td><td>0</td><td>0</td><td>0</td></tr> <tr><td>19時～20時</td><td>8</td><td>160</td><td>168</td><td>0</td><td>0</td><td>0</td><td>1</td><td>9</td><td>10</td><td>0</td><td>0</td><td>0</td><td>1</td><td>319</td><td>320</td><td>0</td><td>0</td><td>0</td></tr> <tr><td>20時～21時</td><td>5</td><td>148</td><td>153</td><td>0</td><td>0</td><td>0</td><td>0</td><td>10</td><td>10</td><td>0</td><td>0</td><td>0</td><td>1</td><td>277</td><td>278</td><td>0</td><td>0</td><td>0</td></tr> <tr><td>21時～22時</td><td>6</td><td>115</td><td>121</td><td>0</td><td>0</td><td>0</td><td>0</td><td>6</td><td>6</td><td>0</td><td>0</td><td>0</td><td>0</td><td>246</td><td>246</td><td>0</td><td>0</td><td>0</td></tr> <tr><td>22時～23時</td><td>4</td><td>89</td><td>93</td><td>0</td><td>0</td><td>0</td><td>0</td><td>4</td><td>4</td><td>0</td><td>0</td><td>0</td><td>0</td><td>221</td><td>221</td><td>0</td><td>0</td><td>0</td></tr> <tr><td>計</td><td>92</td><td>2,546</td><td>2,638</td><td>0</td><td>0</td><td>0</td><td>16</td><td>161</td><td>177</td><td>0</td><td>0</td><td>0</td><td>24</td><td>5,170</td><td>5,194</td><td>0</td><td>0</td><td>0</td></tr> </table>																		8時～9時	4	149	153	0	0	0	1	7	8	0	0	0	1	255	256	0	0	0	9時～10時	4	166	170	0	0	0	2	9	11	0	0	0	1	289	290	0	0	0	10時～11時	5	181	186	0	0	0	2	13	15	0	0	0	2	328	330	0	0	0	11時～12時	3	188	191	0	0	0	1	18	19	0	0	0	2	384	386	0	0	0	12時～13時	8	193	201	0	0	0	0	13	13	0	0	0	1	443	444	0	0	0	13時～14時	10	211	221	0	0	0	1	11	12	0	0	0	2	504	506	0	0	0	14時～15時	6	199	205	0	0	0	0	7	7	0	0	0	5	387	392	0	0	0	15時～16時	8	144	152	0	0	0	2	10	12	0	0	0	2	406	408	0	0	0	16時～17時	8	216	224	0	0	0	1	12	13	0	0	0	3	380	383	0	0	0	17時～18時	7	209	216	0	0	0	3	19	22	0	0	0	1	377	378	0	0	0	18時～19時	6	178	184	0	0	0	2	13	15	0	0	0	2	354	356	0	0	0	19時～20時	8	160	168	0	0	0	1	9	10	0	0	0	1	319	320	0	0	0	20時～21時	5	148	153	0	0	0	0	10	10	0	0	0	1	277	278	0	0	0	21時～22時	6	115	121	0	0	0	0	6	6	0	0	0	0	246	246	0	0	0	22時～23時	4	89	93	0	0	0	0	4	4	0	0	0	0	221	221	0	0	0	計	92	2,546	2,638	0	0	0	16	161	177	0	0	0	24	5,170	5,194	0	0	0
8時～9時	4	149	153	0	0	0	1	7	8	0	0	0	1	255	256	0	0	0																																																																																																																																																																																																																																																																																																																
9時～10時	4	166	170	0	0	0	2	9	11	0	0	0	1	289	290	0	0	0																																																																																																																																																																																																																																																																																																																
10時～11時	5	181	186	0	0	0	2	13	15	0	0	0	2	328	330	0	0	0																																																																																																																																																																																																																																																																																																																
11時～12時	3	188	191	0	0	0	1	18	19	0	0	0	2	384	386	0	0	0																																																																																																																																																																																																																																																																																																																
12時～13時	8	193	201	0	0	0	0	13	13	0	0	0	1	443	444	0	0	0																																																																																																																																																																																																																																																																																																																
13時～14時	10	211	221	0	0	0	1	11	12	0	0	0	2	504	506	0	0	0																																																																																																																																																																																																																																																																																																																
14時～15時	6	199	205	0	0	0	0	7	7	0	0	0	5	387	392	0	0	0																																																																																																																																																																																																																																																																																																																
15時～16時	8	144	152	0	0	0	2	10	12	0	0	0	2	406	408	0	0	0																																																																																																																																																																																																																																																																																																																
16時～17時	8	216	224	0	0	0	1	12	13	0	0	0	3	380	383	0	0	0																																																																																																																																																																																																																																																																																																																
17時～18時	7	209	216	0	0	0	3	19	22	0	0	0	1	377	378	0	0	0																																																																																																																																																																																																																																																																																																																
18時～19時	6	178	184	0	0	0	2	13	15	0	0	0	2	354	356	0	0	0																																																																																																																																																																																																																																																																																																																
19時～20時	8	160	168	0	0	0	1	9	10	0	0	0	1	319	320	0	0	0																																																																																																																																																																																																																																																																																																																
20時～21時	5	148	153	0	0	0	0	10	10	0	0	0	1	277	278	0	0	0																																																																																																																																																																																																																																																																																																																
21時～22時	6	115	121	0	0	0	0	6	6	0	0	0	0	246	246	0	0	0																																																																																																																																																																																																																																																																																																																
22時～23時	4	89	93	0	0	0	0	4	4	0	0	0	0	221	221	0	0	0																																																																																																																																																																																																																																																																																																																
計	92	2,546	2,638	0	0	0	16	161	177	0	0	0	24	5,170	5,194	0	0	0																																																																																																																																																																																																																																																																																																																

調査方向区分	CからBへ右折 方向7			CからAへ直進 方向8			CからDへ左折 方向9			DからCへ右折 方向10			DからBへ直進 方向11			DからAへ左折 方向12																																																																																																																																																																																																																																																																																																																		
時刻	大型車	小型車	合計	大型車	小型車	合計	大型車	小型車	合計	大型車	小型車	合計	大型車	小型車	合計	大型車	小型車	合計																																																																																																																																																																																																																																																																																																																
<table border="1"> <tr><td>8時～9時</td><td>0</td><td>0</td><td>0</td><td>0</td><td>0</td><td>0</td><td>0</td><td>0</td><td>0</td><td>0</td><td>0</td><td>0</td><td>3</td><td>283</td><td>286</td><td>3</td><td>134</td><td>137</td></tr> <tr><td>9時～10時</td><td>0</td><td>0</td><td>0</td><td>0</td><td>0</td><td>0</td><td>0</td><td>0</td><td>0</td><td>0</td><td>0</td><td>0</td><td>4</td><td>310</td><td>314</td><td>3</td><td>165</td><td>168</td></tr> <tr><td>10時～11時</td><td>0</td><td>0</td><td>0</td><td>0</td><td>0</td><td>0</td><td>0</td><td>0</td><td>0</td><td>0</td><td>0</td><td>0</td><td>2</td><td>353</td><td>355</td><td>5</td><td>180</td><td>185</td></tr> <tr><td>11時～12時</td><td>0</td><td>0</td><td>0</td><td>0</td><td>0</td><td>0</td><td>0</td><td>0</td><td>0</td><td>0</td><td>0</td><td>0</td><td>3</td><td>376</td><td>379</td><td>2</td><td>144</td><td>146</td></tr> <tr><td>12時～13時</td><td>0</td><td>0</td><td>0</td><td>0</td><td>0</td><td>0</td><td>0</td><td>0</td><td>0</td><td>0</td><td>0</td><td>0</td><td>4</td><td>380</td><td>384</td><td>1</td><td>192</td><td>193</td></tr> <tr><td>13時～14時</td><td>0</td><td>0</td><td>0</td><td>0</td><td>0</td><td>0</td><td>0</td><td>0</td><td>0</td><td>0</td><td>0</td><td>0</td><td>4</td><td>396</td><td>400</td><td>2</td><td>183</td><td>185</td></tr> <tr><td>14時～15時</td><td>0</td><td>0</td><td>0</td><td>0</td><td>0</td><td>0</td><td>0</td><td>0</td><td>0</td><td>0</td><td>0</td><td>0</td><td>2</td><td>385</td><td>387</td><td>2</td><td>168</td><td>170</td></tr> <tr><td>15時～16時</td><td>0</td><td>0</td><td>0</td><td>0</td><td>0</td><td>0</td><td>0</td><td>0</td><td>0</td><td>0</td><td>0</td><td>0</td><td>4</td><td>324</td><td>328</td><td>4</td><td>145</td><td>149</td></tr> <tr><td>16時～17時</td><td>0</td><td>0</td><td>0</td><td>0</td><td>0</td><td>0</td><td>0</td><td>0</td><td>0</td><td>0</td><td>0</td><td>0</td><td>7</td><td>343</td><td>350</td><td>3</td><td>154</td><td>157</td></tr> <tr><td>17時～18時</td><td>0</td><td>0</td><td>0</td><td>0</td><td>0</td><td>0</td><td>0</td><td>0</td><td>0</td><td>0</td><td>0</td><td>0</td><td>5</td><td>328</td><td>333</td><td>5</td><td>139</td><td>144</td></tr> <tr><td>18時～19時</td><td>0</td><td>0</td><td>0</td><td>0</td><td>0</td><td>0</td><td>0</td><td>0</td><td>0</td><td>0</td><td>0</td><td>0</td><td>4</td><td>296</td><td>300</td><td>3</td><td>127</td><td>130</td></tr> <tr><td>19時～20時</td><td>0</td><td>0</td><td>0</td><td>0</td><td>0</td><td>0</td><td>0</td><td>0</td><td>0</td><td>0</td><td>0</td><td>0</td><td>4</td><td>264</td><td>268</td><td>4</td><td>111</td><td>115</td></tr> <tr><td>20時～21時</td><td>0</td><td>0</td><td>0</td><td>0</td><td>0</td><td>0</td><td>0</td><td>0</td><td>0</td><td>0</td><td>0</td><td>0</td><td>5</td><td>225</td><td>230</td><td>3</td><td>97</td><td>100</td></tr> <tr><td>21時～22時</td><td>0</td><td>0</td><td>0</td><td>0</td><td>0</td><td>0</td><td>0</td><td>0</td><td>0</td><td>0</td><td>0</td><td>0</td><td>3</td><td>197</td><td>200</td><td>2</td><td>75</td><td>77</td></tr> <tr><td>22時～23時</td><td>0</td><td>0</td><td>0</td><td>0</td><td>0</td><td>0</td><td>0</td><td>0</td><td>0</td><td>0</td><td>0</td><td>0</td><td>2</td><td>173</td><td>175</td><td>2</td><td>60</td><td>62</td></tr> <tr><td>計</td><td>0</td><td>0</td><td>0</td><td>0</td><td>0</td><td>0</td><td>0</td><td>0</td><td>0</td><td>0</td><td>0</td><td>0</td><td>56</td><td>4,633</td><td>4,689</td><td>44</td><td>2,074</td><td>2,118</td></tr> </table>																			8時～9時	0	0	0	0	0	0	0	0	0	0	0	0	3	283	286	3	134	137	9時～10時	0	0	0	0	0	0	0	0	0	0	0	0	4	310	314	3	165	168	10時～11時	0	0	0	0	0	0	0	0	0	0	0	0	2	353	355	5	180	185	11時～12時	0	0	0	0	0	0	0	0	0	0	0	0	3	376	379	2	144	146	12時～13時	0	0	0	0	0	0	0	0	0	0	0	0	4	380	384	1	192	193	13時～14時	0	0	0	0	0	0	0	0	0	0	0	0	4	396	400	2	183	185	14時～15時	0	0	0	0	0	0	0	0	0	0	0	0	2	385	387	2	168	170	15時～16時	0	0	0	0	0	0	0	0	0	0	0	0	4	324	328	4	145	149	16時～17時	0	0	0	0	0	0	0	0	0	0	0	0	7	343	350	3	154	157	17時～18時	0	0	0	0	0	0	0	0	0	0	0	0	5	328	333	5	139	144	18時～19時	0	0	0	0	0	0	0	0	0	0	0	0	4	296	300	3	127	130	19時～20時	0	0	0	0	0	0	0	0	0	0	0	0	4	264	268	4	111	115	20時～21時	0	0	0	0	0	0	0	0	0	0	0	0	5	225	230	3	97	100	21時～22時	0	0	0	0	0	0	0	0	0	0	0	0	3	197	200	2	75	77	22時～23時	0	0	0	0	0	0	0	0	0	0	0	0	2	173	175	2	60	62	計	0	0	0	0	0	0	0	0	0	0	0	0	56	4,633	4,689	44	2,074	2,118
8時～9時	0	0	0	0	0	0	0	0	0	0	0	0	3	283	286	3	134	137																																																																																																																																																																																																																																																																																																																
9時～10時	0	0	0	0	0	0	0	0	0	0	0	0	4	310	314	3	165	168																																																																																																																																																																																																																																																																																																																
10時～11時	0	0	0	0	0	0	0	0	0	0	0	0	2	353	355	5	180	185																																																																																																																																																																																																																																																																																																																
11時～12時	0	0	0	0	0	0	0	0	0	0	0	0	3	376	379	2	144	146																																																																																																																																																																																																																																																																																																																
12時～13時	0	0	0	0	0	0	0	0	0	0	0	0	4	380	384	1	192	193																																																																																																																																																																																																																																																																																																																
13時～14時	0	0	0	0	0	0	0	0	0	0	0	0	4	396	400	2	183	185																																																																																																																																																																																																																																																																																																																
14時～15時	0	0	0	0	0	0	0	0	0	0	0	0	2	385	387	2	168	170																																																																																																																																																																																																																																																																																																																
15時～16時	0	0	0	0	0	0	0	0	0	0	0	0	4	324	328	4	145	149																																																																																																																																																																																																																																																																																																																
16時～17時	0	0	0	0	0	0	0	0	0	0	0	0	7	343	350	3	154	157																																																																																																																																																																																																																																																																																																																
17時～18時	0	0	0	0	0	0	0	0	0	0	0	0	5	328	333	5	139	144																																																																																																																																																																																																																																																																																																																
18時～19時	0	0	0	0	0	0	0	0	0	0	0	0	4	296	300	3	127	130																																																																																																																																																																																																																																																																																																																
19時～20時	0	0	0	0	0	0	0	0	0	0	0	0	4	264	268	4	111	115																																																																																																																																																																																																																																																																																																																
20時～21時	0	0	0	0	0	0	0	0	0	0	0	0	5	225	230	3	97	100																																																																																																																																																																																																																																																																																																																
21時～22時	0	0	0	0	0	0	0	0	0	0	0	0	3	197	200	2	75	77																																																																																																																																																																																																																																																																																																																
22時～23時	0	0	0	0	0	0	0	0	0	0	0	0	2	173	175	2	60	62																																																																																																																																																																																																																																																																																																																
計	0	0	0	0	0	0	0	0	0	0	0	0	56	4,633	4,689	44	2,074	2,118																																																																																																																																																																																																																																																																																																																

調査方向区分	全方向			
時刻	大型車	小型車	合計	大型車混入率(%)
8時～9時	12	828	840	1.4
9時～10時	14	939	953	1.5
10時～11時	16	1,055	1,071	1.5
11時～12時	11	1,110	1,121	1.0
12時～13時	14	1,221	1,235	1.1
13時～14時	19	1,305	1,324	1.4
14時～15時	15	1,146	1,161	1.3
15時～16時	20	1,029	1,049	1.9
16時～17時	22	1,105	1,127	2.0
17時～18時	21	1,072	1,093	1.9
18時～19時	17	968	985	1.7
19時～20時	18	863	881	2.0
20時～21時	14	757	771	1.8
21時～22時	11	639	650	1.7
22時～23時	8	547	555	1.4
計	232	14,584	14,816	1.6

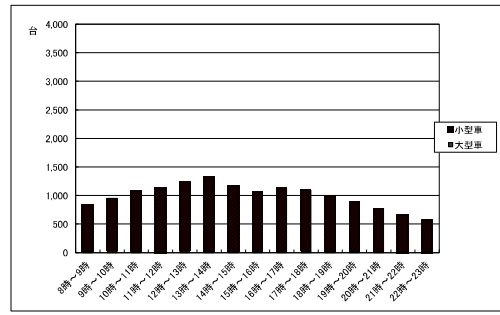

地点	No.2																																																																																																																																																																																																																																																																																																																																	
調査日	令和7年10月26日(日)																																																																																																																																																																																																																																																																																																																																	
天候	曇り																																																																																																																																																																																																																																																																																																																																	
概要	当交差点の交通量ピークは14時～15時であった。																																																																																																																																																																																																																																																																																																																																	
調査方向区分	AからDへ右折 方向1			AからCへ直進 方向2			AからBへ左折 方向3			BからAへ右折 方向4			BからDへ直進 方向5			BからCへ左折 方向6																																																																																																																																																																																																																																																																																																																		
車両区分	大型車	小型車	合計	大型車	小型車	合計	大型車	小型車	合計	大型車	小型車	合計	大型車	小型車	合計	大型車	小型車	合計																																																																																																																																																																																																																																																																																																																
時刻	<table border="1"> <tr><td>8時～9時</td><td>1</td><td>40</td><td>41</td><td>4</td><td>236</td><td>240</td><td>2</td><td>12</td><td>14</td><td>4</td><td>32</td><td>36</td><td>3</td><td>320</td><td>323</td><td>8</td><td>148</td><td>156</td></tr> <tr><td>9時～10時</td><td>1</td><td>49</td><td>50</td><td>3</td><td>221</td><td>224</td><td>0</td><td>10</td><td>10</td><td>2</td><td>27</td><td>29</td><td>6</td><td>367</td><td>373</td><td>4</td><td>108</td><td>112</td></tr> <tr><td>10時～11時</td><td>3</td><td>75</td><td>78</td><td>5</td><td>225</td><td>230</td><td>1</td><td>11</td><td>12</td><td>1</td><td>32</td><td>33</td><td>9</td><td>434</td><td>443</td><td>3</td><td>121</td><td>124</td></tr> <tr><td>11時～12時</td><td>1</td><td>64</td><td>65</td><td>8</td><td>238</td><td>246</td><td>2</td><td>10</td><td>12</td><td>2</td><td>42</td><td>44</td><td>8</td><td>390</td><td>398</td><td>6</td><td>142</td><td>148</td></tr> <tr><td>12時～13時</td><td>0</td><td>61</td><td>61</td><td>3</td><td>188</td><td>191</td><td>1</td><td>18</td><td>19</td><td>1</td><td>31</td><td>32</td><td>5</td><td>358</td><td>363</td><td>2</td><td>133</td><td>135</td></tr> <tr><td>13時～14時</td><td>2</td><td>57</td><td>59</td><td>1</td><td>139</td><td>140</td><td>0</td><td>13</td><td>13</td><td>3</td><td>27</td><td>30</td><td>6</td><td>321</td><td>327</td><td>3</td><td>120</td><td>123</td></tr> <tr><td>14時～15時</td><td>0</td><td>74</td><td>74</td><td>2</td><td>231</td><td>233</td><td>0</td><td>12</td><td>12</td><td>1</td><td>35</td><td>36</td><td>6</td><td>441</td><td>447</td><td>7</td><td>139</td><td>146</td></tr> <tr><td>15時～16時</td><td>1</td><td>54</td><td>55</td><td>1</td><td>240</td><td>241</td><td>1</td><td>9</td><td>10</td><td>2</td><td>26</td><td>28</td><td>2</td><td>372</td><td>374</td><td>2</td><td>174</td><td>176</td></tr> <tr><td>16時～17時</td><td>0</td><td>50</td><td>50</td><td>3</td><td>239</td><td>242</td><td>0</td><td>5</td><td>5</td><td>0</td><td>41</td><td>41</td><td>3</td><td>402</td><td>405</td><td>4</td><td>133</td><td>137</td></tr> <tr><td>17時～18時</td><td>2</td><td>61</td><td>63</td><td>2</td><td>188</td><td>190</td><td>0</td><td>13</td><td>13</td><td>1</td><td>48</td><td>49</td><td>6</td><td>366</td><td>372</td><td>1</td><td>122</td><td>123</td></tr> <tr><td>18時～19時</td><td>1</td><td>49</td><td>50</td><td>2</td><td>165</td><td>167</td><td>0</td><td>10</td><td>10</td><td>2</td><td>37</td><td>39</td><td>5</td><td>331</td><td>336</td><td>1</td><td>108</td><td>109</td></tr> <tr><td>19時～20時</td><td>1</td><td>44</td><td>45</td><td>3</td><td>140</td><td>143</td><td>1</td><td>8</td><td>9</td><td>1</td><td>31</td><td>32</td><td>3</td><td>288</td><td>291</td><td>2</td><td>88</td><td>90</td></tr> <tr><td>20時～21時</td><td>0</td><td>37</td><td>37</td><td>2</td><td>122</td><td>124</td><td>0</td><td>7</td><td>7</td><td>0</td><td>29</td><td>29</td><td>3</td><td>230</td><td>233</td><td>0</td><td>67</td><td>67</td></tr> <tr><td>21時～22時</td><td>0</td><td>31</td><td>31</td><td>1</td><td>98</td><td>99</td><td>1</td><td>4</td><td>5</td><td>0</td><td>26</td><td>26</td><td>2</td><td>174</td><td>176</td><td>1</td><td>51</td><td>52</td></tr> <tr><td>22時～23時</td><td>0</td><td>19</td><td>19</td><td>2</td><td>70</td><td>72</td><td>0</td><td>3</td><td>3</td><td>0</td><td>20</td><td>20</td><td>0</td><td>135</td><td>135</td><td>2</td><td>30</td><td>32</td></tr> <tr><td>計</td><td>13</td><td>765</td><td>778</td><td>42</td><td>2,740</td><td>2,782</td><td>9</td><td>145</td><td>154</td><td>20</td><td>484</td><td>504</td><td>67</td><td>4,929</td><td>4,996</td><td>46</td><td>1,684</td><td>1,730</td></tr> </table>																		8時～9時	1	40	41	4	236	240	2	12	14	4	32	36	3	320	323	8	148	156	9時～10時	1	49	50	3	221	224	0	10	10	2	27	29	6	367	373	4	108	112	10時～11時	3	75	78	5	225	230	1	11	12	1	32	33	9	434	443	3	121	124	11時～12時	1	64	65	8	238	246	2	10	12	2	42	44	8	390	398	6	142	148	12時～13時	0	61	61	3	188	191	1	18	19	1	31	32	5	358	363	2	133	135	13時～14時	2	57	59	1	139	140	0	13	13	3	27	30	6	321	327	3	120	123	14時～15時	0	74	74	2	231	233	0	12	12	1	35	36	6	441	447	7	139	146	15時～16時	1	54	55	1	240	241	1	9	10	2	26	28	2	372	374	2	174	176	16時～17時	0	50	50	3	239	242	0	5	5	0	41	41	3	402	405	4	133	137	17時～18時	2	61	63	2	188	190	0	13	13	1	48	49	6	366	372	1	122	123	18時～19時	1	49	50	2	165	167	0	10	10	2	37	39	5	331	336	1	108	109	19時～20時	1	44	45	3	140	143	1	8	9	1	31	32	3	288	291	2	88	90	20時～21時	0	37	37	2	122	124	0	7	7	0	29	29	3	230	233	0	67	67	21時～22時	0	31	31	1	98	99	1	4	5	0	26	26	2	174	176	1	51	52	22時～23時	0	19	19	2	70	72	0	3	3	0	20	20	0	135	135	2	30	32	計	13	765	778	42	2,740	2,782	9	145	154	20	484	504	67	4,929	4,996	46	1,684	1,730
8時～9時	1	40	41	4	236	240	2	12	14	4	32	36	3	320	323	8	148	156																																																																																																																																																																																																																																																																																																																
9時～10時	1	49	50	3	221	224	0	10	10	2	27	29	6	367	373	4	108	112																																																																																																																																																																																																																																																																																																																
10時～11時	3	75	78	5	225	230	1	11	12	1	32	33	9	434	443	3	121	124																																																																																																																																																																																																																																																																																																																
11時～12時	1	64	65	8	238	246	2	10	12	2	42	44	8	390	398	6	142	148																																																																																																																																																																																																																																																																																																																
12時～13時	0	61	61	3	188	191	1	18	19	1	31	32	5	358	363	2	133	135																																																																																																																																																																																																																																																																																																																
13時～14時	2	57	59	1	139	140	0	13	13	3	27	30	6	321	327	3	120	123																																																																																																																																																																																																																																																																																																																
14時～15時	0	74	74	2	231	233	0	12	12	1	35	36	6	441	447	7	139	146																																																																																																																																																																																																																																																																																																																
15時～16時	1	54	55	1	240	241	1	9	10	2	26	28	2	372	374	2	174	176																																																																																																																																																																																																																																																																																																																
16時～17時	0	50	50	3	239	242	0	5	5	0	41	41	3	402	405	4	133	137																																																																																																																																																																																																																																																																																																																
17時～18時	2	61	63	2	188	190	0	13	13	1	48	49	6	366	372	1	122	123																																																																																																																																																																																																																																																																																																																
18時～19時	1	49	50	2	165	167	0	10	10	2	37	39	5	331	336	1	108	109																																																																																																																																																																																																																																																																																																																
19時～20時	1	44	45	3	140	143	1	8	9	1	31	32	3	288	291	2	88	90																																																																																																																																																																																																																																																																																																																
20時～21時	0	37	37	2	122	124	0	7	7	0	29	29	3	230	233	0	67	67																																																																																																																																																																																																																																																																																																																
21時～22時	0	31	31	1	98	99	1	4	5	0	26	26	2	174	176	1	51	52																																																																																																																																																																																																																																																																																																																
22時～23時	0	19	19	2	70	72	0	3	3	0	20	20	0	135	135	2	30	32																																																																																																																																																																																																																																																																																																																
計	13	765	778	42	2,740	2,782	9	145	154	20	484	504	67	4,929	4,996	46	1,684	1,730																																																																																																																																																																																																																																																																																																																

調査方向区分	CからBへ右折 方向7			CからAへ直進 方向8			CからDへ左折 方向9			DからCへ右折 方向10			DからBへ直進 方向11			DからAへ左折 方向12																																																																																																																																																																																																																																																																																																																		
車両区分	大型車	小型車	合計	大型車	小型車	合計	大型車	小型車	合計	大型車	小型車	合計	大型車	小型車	合計	大型車	小型車	合計																																																																																																																																																																																																																																																																																																																
時刻	<table border="1"> <tr><td>8時～9時</td><td>3</td><td>112</td><td>115</td><td>4</td><td>188</td><td>192</td><td>0</td><td>100</td><td>100</td><td>2</td><td>64</td><td>66</td><td>8</td><td>232</td><td>240</td><td>2</td><td>40</td><td>42</td></tr> <tr><td>9時～10時</td><td>5</td><td>92</td><td>97</td><td>8</td><td>224</td><td>232</td><td>0</td><td>119</td><td>119</td><td>0</td><td>86</td><td>86</td><td>5</td><td>308</td><td>313</td><td>1</td><td>47</td><td>48</td></tr> <tr><td>10時～11時</td><td>1</td><td>104</td><td>105</td><td>2</td><td>173</td><td>175</td><td>0</td><td>131</td><td>131</td><td>1</td><td>114</td><td>115</td><td>9</td><td>378</td><td>387</td><td>2</td><td>77</td><td>79</td></tr> <tr><td>11時～12時</td><td>2</td><td>94</td><td>96</td><td>2</td><td>184</td><td>186</td><td>0</td><td>146</td><td>146</td><td>2</td><td>138</td><td>140</td><td>6</td><td>350</td><td>356</td><td>2</td><td>68</td><td>70</td></tr> <tr><td>12時～13時</td><td>0</td><td>82</td><td>82</td><td>2</td><td>155</td><td>157</td><td>1</td><td>127</td><td>128</td><td>2</td><td>131</td><td>133</td><td>5</td><td>321</td><td>326</td><td>1</td><td>54</td><td>55</td></tr> <tr><td>13時～14時</td><td>1</td><td>69</td><td>70</td><td>3</td><td>118</td><td>121</td><td>1</td><td>108</td><td>109</td><td>1</td><td>126</td><td>127</td><td>6</td><td>282</td><td>288</td><td>0</td><td>58</td><td>58</td></tr> <tr><td>14時～15時</td><td>0</td><td>99</td><td>99</td><td>1</td><td>177</td><td>178</td><td>0</td><td>115</td><td>115</td><td>4</td><td>140</td><td>144</td><td>6</td><td>383</td><td>389</td><td>1</td><td>72</td><td>73</td></tr> <tr><td>15時～16時</td><td>1</td><td>103</td><td>104</td><td>2</td><td>148</td><td>150</td><td>0</td><td>101</td><td>101</td><td>3</td><td>156</td><td>159</td><td>4</td><td>351</td><td>355</td><td>0</td><td>59</td><td>59</td></tr> <tr><td>16時～17時</td><td>1</td><td>50</td><td>51</td><td>0</td><td>160</td><td>160</td><td>1</td><td>105</td><td>106</td><td>2</td><td>137</td><td>139</td><td>4</td><td>363</td><td>367</td><td>2</td><td>52</td><td>54</td></tr> <tr><td>17時～18時</td><td>2</td><td>64</td><td>66</td><td>1</td><td>145</td><td>146</td><td>0</td><td>88</td><td>88</td><td>2</td><td>128</td><td>130</td><td>3</td><td>321</td><td>324</td><td>0</td><td>56</td><td>56</td></tr> <tr><td>18時～19時</td><td>1</td><td>71</td><td>72</td><td>1</td><td>139</td><td>140</td><td>0</td><td>70</td><td>70</td><td>2</td><td>111</td><td>113</td><td>2</td><td>299</td><td>301</td><td>1</td><td>48</td><td>49</td></tr> <tr><td>19時～20時</td><td>0</td><td>52</td><td>52</td><td>2</td><td>121</td><td>123</td><td>0</td><td>69</td><td>69</td><td>3</td><td>92</td><td>95</td><td>2</td><td>274</td><td>276</td><td>1</td><td>40</td><td>41</td></tr> <tr><td>20時～21時</td><td>0</td><td>47</td><td>47</td><td>0</td><td>104</td><td>104</td><td>0</td><td>55</td><td>55</td><td>2</td><td>78</td><td>80</td><td>3</td><td>243</td><td>246</td><td>0</td><td>43</td><td>43</td></tr> <tr><td>21時～22時</td><td>1</td><td>30</td><td>31</td><td>1</td><td>76</td><td>77</td><td>0</td><td>41</td><td>41</td><td>1</td><td>62</td><td>63</td><td>2</td><td>186</td><td>188</td><td>0</td><td>39</td><td>39</td></tr> <tr><td>22時～23時</td><td>0</td><td>28</td><td>28</td><td>0</td><td>50</td><td>50</td><td>0</td><td>30</td><td>30</td><td>0</td><td>51</td><td>51</td><td>3</td><td>145</td><td>148</td><td>0</td><td>33</td><td>33</td></tr> <tr><td>計</td><td>18</td><td>1,097</td><td>1,115</td><td>29</td><td>2,162</td><td>2,191</td><td>3</td><td>1,405</td><td>1,408</td><td>27</td><td>1,614</td><td>1,641</td><td>68</td><td>4,436</td><td>4,504</td><td>13</td><td>786</td><td>799</td></tr> </table>																		8時～9時	3	112	115	4	188	192	0	100	100	2	64	66	8	232	240	2	40	42	9時～10時	5	92	97	8	224	232	0	119	119	0	86	86	5	308	313	1	47	48	10時～11時	1	104	105	2	173	175	0	131	131	1	114	115	9	378	387	2	77	79	11時～12時	2	94	96	2	184	186	0	146	146	2	138	140	6	350	356	2	68	70	12時～13時	0	82	82	2	155	157	1	127	128	2	131	133	5	321	326	1	54	55	13時～14時	1	69	70	3	118	121	1	108	109	1	126	127	6	282	288	0	58	58	14時～15時	0	99	99	1	177	178	0	115	115	4	140	144	6	383	389	1	72	73	15時～16時	1	103	104	2	148	150	0	101	101	3	156	159	4	351	355	0	59	59	16時～17時	1	50	51	0	160	160	1	105	106	2	137	139	4	363	367	2	52	54	17時～18時	2	64	66	1	145	146	0	88	88	2	128	130	3	321	324	0	56	56	18時～19時	1	71	72	1	139	140	0	70	70	2	111	113	2	299	301	1	48	49	19時～20時	0	52	52	2	121	123	0	69	69	3	92	95	2	274	276	1	40	41	20時～21時	0	47	47	0	104	104	0	55	55	2	78	80	3	243	246	0	43	43	21時～22時	1	30	31	1	76	77	0	41	41	1	62	63	2	186	188	0	39	39	22時～23時	0	28	28	0	50	50	0	30	30	0	51	51	3	145	148	0	33	33	計	18	1,097	1,115	29	2,162	2,191	3	1,405	1,408	27	1,614	1,641	68	4,436	4,504	13	786	799
8時～9時	3	112	115	4	188	192	0	100	100	2	64	66	8	232	240	2	40	42																																																																																																																																																																																																																																																																																																																
9時～10時	5	92	97	8	224	232	0	119	119	0	86	86	5	308	313	1	47	48																																																																																																																																																																																																																																																																																																																
10時～11時	1	104	105	2	173	175	0	131	131	1	114	115	9	378	387	2	77	79																																																																																																																																																																																																																																																																																																																
11時～12時	2	94	96	2	184	186	0	146	146	2	138	140	6	350	356	2	68	70																																																																																																																																																																																																																																																																																																																
12時～13時	0	82	82	2	155	157	1	127	128	2	131	133	5	321	326	1	54	55																																																																																																																																																																																																																																																																																																																
13時～14時	1	69	70	3	118	121	1	108	109	1	126	127	6	282	288	0	58	58																																																																																																																																																																																																																																																																																																																
14時～15時	0	99	99	1	177	178	0	115	115	4	140	144	6	383	389	1	72	73																																																																																																																																																																																																																																																																																																																
15時～16時	1	103	104	2	148	150	0	101	101	3	156	159	4	351	355	0	59	59																																																																																																																																																																																																																																																																																																																
16時～17時	1	50	51	0	160	160	1	105	106	2	137	139	4	363	367	2	52	54																																																																																																																																																																																																																																																																																																																
17時～18時	2	64	66	1	145	146	0	88	88	2	128	130	3	321	324	0	56	56																																																																																																																																																																																																																																																																																																																
18時～19時	1	71	72	1	139	140	0	70	70	2	111	113	2	299	301	1	48	49																																																																																																																																																																																																																																																																																																																
19時～20時	0	52	52	2	121	123	0	69	69	3	92	95	2	274	276	1	40	41																																																																																																																																																																																																																																																																																																																
20時～21時	0	47	47	0	104	104	0	55	55	2	78	80	3	243	246	0	43	43																																																																																																																																																																																																																																																																																																																
21時～22時	1	30	31	1	76	77	0	41	41	1	62	63	2	186	188	0	39	39																																																																																																																																																																																																																																																																																																																
22時～23時	0	28	28	0	50	50	0	30	30	0	51	51	3	145	148	0	33	33																																																																																																																																																																																																																																																																																																																
計	18	1,097	1,115	29	2,162	2,191	3	1,405	1,408	27	1,614	1,641	68	4,436	4,504	13	786	799																																																																																																																																																																																																																																																																																																																

調査方向区分	全方向																																																																																			
車両区分	大型車	小型車	合計	大型車混入率(%)																																																																																
時刻	<table border="1"> <tr><td>8時～9時</td><td>41</td><td>1,524</td><td>1,565</td><td>2.6</td></tr> <tr><td>9時～10時</td><td>35</td><td>1,658</td><td>1,693</td><td>2.1</td></tr> <tr><td>10時～11時</td><td>37</td><td>1,875</td><td>1,912</td><td>1.9</td></tr> <tr><td>11時～12時</td><td>41</td><td>1,866</td><td>1,907</td><td>2.1</td></tr> <tr><td>12時～13時</td><td>23</td><td>1,659</td><td>1,682</td><td>1.4</td></tr> <tr><td>13時～14時</td><td>27</td><td>1,438</td><td>1,465</td><td>1.8</td></tr> <tr><td>14時～15時</td><td>28</td><td>1,918</td><td>1,946</td><td>1.4</td></tr> <tr><td>15時～16時</td><td>19</td><td>1,793</td><td>1,812</td><td>1.0</td></tr> <tr><td>16時～17時</td><td>20</td><td>1,737</td><td>1,757</td><td>1.1</td></tr> <tr><td>17時～18時</td><td>20</td><td>1,600</td><td>1,620</td><td>1.2</td></tr> <tr><td>18時～19時</td><td>18</td><td>1,438</td><td>1,456</td><td>1.2</td></tr> <tr><td>19時～20時</td><td>19</td><td>1,247</td><td>1,266</td><td>1.5</td></tr> <tr><td>20時～21時</td><td>10</td><td>1,062</td><td>1,072</td><td>0.9</td></tr> <tr><td>21時～22時</td><td>10</td><td>818</td><td>828</td><td>1.2</td></tr> <tr><td>22時～23時</td><td>7</td><td>614</td><td>621</td><td>1.1</td></tr> <tr><td>計</td><td>355</td><td>22,247</td><td>22,602</td><td>1.6</td></tr> </table>				8時～9時	41	1,524	1,565	2.6	9時～10時	35	1,658	1,693	2.1	10時～11時	37	1,875	1,912	1.9	11時～12時	41	1,866	1,907	2.1	12時～13時	23	1,659	1,682	1.4	13時～14時	27	1,438	1,465	1.8	14時～15時	28	1,918	1,946	1.4	15時～16時	19	1,793	1,812	1.0	16時～17時	20	1,737	1,757	1.1	17時～18時	20	1,600	1,620	1.2	18時～19時	18	1,438	1,456	1.2	19時～20時	19	1,247	1,266	1.5	20時～21時	10	1,062	1,072	0.9	21時～22時	10	818	828	1.2	22時～23時	7	614	621	1.1	計	355	22,247	22,602	1.6
8時～9時	41	1,524	1,565	2.6																																																																																
9時～10時	35	1,658	1,693	2.1																																																																																
10時～11時	37	1,875	1,912	1.9																																																																																
11時～12時	41	1,866	1,907	2.1																																																																																
12時～13時	23	1,659	1,682	1.4																																																																																
13時～14時	27	1,438	1,465	1.8																																																																																
14時～15時	28	1,918	1,946	1.4																																																																																
15時～16時	19	1,793	1,812	1.0																																																																																
16時～17時	20	1,737	1,757	1.1																																																																																
17時～18時	20	1,600	1,620	1.2																																																																																
18時～19時	18	1,438	1,456	1.2																																																																																
19時～20時	19	1,247	1,266	1.5																																																																																
20時～21時	10	1,062	1,072	0.9																																																																																
21時～22時	10	818	828	1.2																																																																																
22時～23時	7	614	621	1.1																																																																																
計	355	22,247	22,602	1.6																																																																																

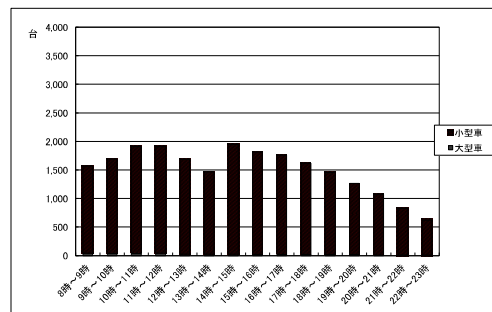

地点	No.3																																																																																																																																																																																																																																																																																																																																	
調査日	令和7年10月26日(日)																																																																																																																																																																																																																																																																																																																																	
天候	曇り																																																																																																																																																																																																																																																																																																																																	
概要	当交差点の交通量ピークは11時～12時であった。																																																																																																																																																																																																																																																																																																																																	
調査方向区分	AからDへ右折 方向1			AからCへ直進 方向2			AからBへ左折 方向3			BからAへ右折 方向4			BからDへ直進 方向5			BからCへ左折 方向6																																																																																																																																																																																																																																																																																																																		
車両区分	大型車	小型車	合計	大型車	小型車	合計	大型車	小型車	合計	大型車	小型車	合計	大型車	小型車	合計	大型車	小型車	合計																																																																																																																																																																																																																																																																																																																
時刻	<table border="1"> <tr><td>8時～9時</td><td>1</td><td>59</td><td>60</td><td>8</td><td>372</td><td>380</td><td>1</td><td>50</td><td>51</td><td>0</td><td>37</td><td>37</td><td>2</td><td>310</td><td>312</td><td>4</td><td>65</td><td>69</td></tr> <tr><td>9時～10時</td><td>1</td><td>55</td><td>56</td><td>11</td><td>398</td><td>409</td><td>1</td><td>56</td><td>57</td><td>2</td><td>45</td><td>47</td><td>2</td><td>332</td><td>334</td><td>2</td><td>76</td><td>78</td></tr> <tr><td>10時～11時</td><td>0</td><td>58</td><td>58</td><td>4</td><td>424</td><td>428</td><td>1</td><td>75</td><td>76</td><td>1</td><td>38</td><td>39</td><td>12</td><td>403</td><td>415</td><td>3</td><td>92</td><td>95</td></tr> <tr><td>11時～12時</td><td>2</td><td>74</td><td>76</td><td>6</td><td>390</td><td>396</td><td>2</td><td>48</td><td>50</td><td>0</td><td>36</td><td>36</td><td>4</td><td>436</td><td>440</td><td>2</td><td>98</td><td>100</td></tr> <tr><td>12時～13時</td><td>1</td><td>70</td><td>71</td><td>8</td><td>425</td><td>433</td><td>0</td><td>69</td><td>69</td><td>0</td><td>49</td><td>49</td><td>6</td><td>372</td><td>378</td><td>4</td><td>87</td><td>91</td></tr> <tr><td>13時～14時</td><td>2</td><td>75</td><td>77</td><td>14</td><td>452</td><td>466</td><td>1</td><td>84</td><td>85</td><td>0</td><td>54</td><td>54</td><td>5</td><td>327</td><td>332</td><td>4</td><td>80</td><td>84</td></tr> <tr><td>14時～15時</td><td>2</td><td>48</td><td>50</td><td>9</td><td>411</td><td>420</td><td>0</td><td>62</td><td>62</td><td>1</td><td>65</td><td>66</td><td>3</td><td>310</td><td>313</td><td>2</td><td>116</td><td>118</td></tr> <tr><td>15時～16時</td><td>2</td><td>42</td><td>44</td><td>10</td><td>429</td><td>439</td><td>0</td><td>42</td><td>42</td><td>2</td><td>75</td><td>77</td><td>2</td><td>321</td><td>323</td><td>1</td><td>104</td><td>105</td></tr> <tr><td>16時～17時</td><td>3</td><td>44</td><td>47</td><td>5</td><td>342</td><td>347</td><td>0</td><td>54</td><td>54</td><td>1</td><td>57</td><td>58</td><td>8</td><td>326</td><td>334</td><td>0</td><td>88</td><td>88</td></tr> <tr><td>17時～18時</td><td>1</td><td>36</td><td>37</td><td>6</td><td>370</td><td>376</td><td>0</td><td>62</td><td>62</td><td>0</td><td>50</td><td>50</td><td>4</td><td>348</td><td>352</td><td>2</td><td>103</td><td>105</td></tr> <tr><td>18時～19時</td><td>0</td><td>45</td><td>45</td><td>5</td><td>331</td><td>336</td><td>1</td><td>49</td><td>50</td><td>0</td><td>47</td><td>47</td><td>3</td><td>332</td><td>335</td><td>1</td><td>110</td><td>111</td></tr> <tr><td>19時～20時</td><td>1</td><td>44</td><td>45</td><td>4</td><td>298</td><td>302</td><td>0</td><td>43</td><td>43</td><td>1</td><td>44</td><td>45</td><td>3</td><td>296</td><td>299</td><td>0</td><td>97</td><td>97</td></tr> <tr><td>20時～21時</td><td>0</td><td>30</td><td>30</td><td>4</td><td>234</td><td>238</td><td>0</td><td>36</td><td>36</td><td>0</td><td>37</td><td>37</td><td>4</td><td>255</td><td>259</td><td>1</td><td>84</td><td>85</td></tr> <tr><td>21時～22時</td><td>1</td><td>39</td><td>40</td><td>3</td><td>188</td><td>191</td><td>0</td><td>35</td><td>35</td><td>0</td><td>39</td><td>39</td><td>5</td><td>190</td><td>195</td><td>1</td><td>74</td><td>75</td></tr> <tr><td>22時～23時</td><td>0</td><td>25</td><td>25</td><td>4</td><td>145</td><td>149</td><td>0</td><td>24</td><td>24</td><td>0</td><td>25</td><td>25</td><td>3</td><td>176</td><td>179</td><td>0</td><td>59</td><td>59</td></tr> <tr><td>計</td><td>17</td><td>744</td><td>761</td><td>101</td><td>5,209</td><td>5,310</td><td>7</td><td>789</td><td>796</td><td>8</td><td>698</td><td>706</td><td>66</td><td>4,734</td><td>4,800</td><td>27</td><td>1,333</td><td>1,360</td></tr> </table>																		8時～9時	1	59	60	8	372	380	1	50	51	0	37	37	2	310	312	4	65	69	9時～10時	1	55	56	11	398	409	1	56	57	2	45	47	2	332	334	2	76	78	10時～11時	0	58	58	4	424	428	1	75	76	1	38	39	12	403	415	3	92	95	11時～12時	2	74	76	6	390	396	2	48	50	0	36	36	4	436	440	2	98	100	12時～13時	1	70	71	8	425	433	0	69	69	0	49	49	6	372	378	4	87	91	13時～14時	2	75	77	14	452	466	1	84	85	0	54	54	5	327	332	4	80	84	14時～15時	2	48	50	9	411	420	0	62	62	1	65	66	3	310	313	2	116	118	15時～16時	2	42	44	10	429	439	0	42	42	2	75	77	2	321	323	1	104	105	16時～17時	3	44	47	5	342	347	0	54	54	1	57	58	8	326	334	0	88	88	17時～18時	1	36	37	6	370	376	0	62	62	0	50	50	4	348	352	2	103	105	18時～19時	0	45	45	5	331	336	1	49	50	0	47	47	3	332	335	1	110	111	19時～20時	1	44	45	4	298	302	0	43	43	1	44	45	3	296	299	0	97	97	20時～21時	0	30	30	4	234	238	0	36	36	0	37	37	4	255	259	1	84	85	21時～22時	1	39	40	3	188	191	0	35	35	0	39	39	5	190	195	1	74	75	22時～23時	0	25	25	4	145	149	0	24	24	0	25	25	3	176	179	0	59	59	計	17	744	761	101	5,209	5,310	7	789	796	8	698	706	66	4,734	4,800	27	1,333	1,360
8時～9時	1	59	60	8	372	380	1	50	51	0	37	37	2	310	312	4	65	69																																																																																																																																																																																																																																																																																																																
9時～10時	1	55	56	11	398	409	1	56	57	2	45	47	2	332	334	2	76	78																																																																																																																																																																																																																																																																																																																
10時～11時	0	58	58	4	424	428	1	75	76	1	38	39	12	403	415	3	92	95																																																																																																																																																																																																																																																																																																																
11時～12時	2	74	76	6	390	396	2	48	50	0	36	36	4	436	440	2	98	100																																																																																																																																																																																																																																																																																																																
12時～13時	1	70	71	8	425	433	0	69	69	0	49	49	6	372	378	4	87	91																																																																																																																																																																																																																																																																																																																
13時～14時	2	75	77	14	452	466	1	84	85	0	54	54	5	327	332	4	80	84																																																																																																																																																																																																																																																																																																																
14時～15時	2	48	50	9	411	420	0	62	62	1	65	66	3	310	313	2	116	118																																																																																																																																																																																																																																																																																																																
15時～16時	2	42	44	10	429	439	0	42	42	2	75	77	2	321	323	1	104	105																																																																																																																																																																																																																																																																																																																
16時～17時	3	44	47	5	342	347	0	54	54	1	57	58	8	326	334	0	88	88																																																																																																																																																																																																																																																																																																																
17時～18時	1	36	37	6	370	376	0	62	62	0	50	50	4	348	352	2	103	105																																																																																																																																																																																																																																																																																																																
18時～19時	0	45	45	5	331	336	1	49	50	0	47	47	3	332	335	1	110	111																																																																																																																																																																																																																																																																																																																
19時～20時	1	44	45	4	298	302	0	43	43	1	44	45	3	296	299	0	97	97																																																																																																																																																																																																																																																																																																																
20時～21時	0	30	30	4	234	238	0	36	36	0	37	37	4	255	259	1	84	85																																																																																																																																																																																																																																																																																																																
21時～22時	1	39	40	3	188	191	0	35	35	0	39	39	5	190	195	1	74	75																																																																																																																																																																																																																																																																																																																
22時～23時	0	25	25	4	145	149	0	24	24	0	25	25	3	176	179	0	59	59																																																																																																																																																																																																																																																																																																																
計	17	744	761	101	5,209	5,310	7	789	796	8	698	706	66	4,734	4,800	27	1,333	1,360																																																																																																																																																																																																																																																																																																																

調査方向区分	CからBへ右折 方向7			CからAへ直進 方向8			CからDへ左折 方向9			DからCへ右折 方向10			DからBへ直進 方向11			DからAへ左折 方向12																																																																																																																																																																																																																																																																																																																		
車両区分	大型車	小型車	合計	大型車	小型車	合計	大型車	小型車	合計	大型車	小型車	合計	大型車	小型車	合計	大型車	小型車	合計																																																																																																																																																																																																																																																																																																																
時刻	<table border="1"> <tr><td>8時～9時</td><td>3</td><td>119</td><td>122</td><td>13</td><td>233</td><td>246</td><td>1</td><td>39</td><td>40</td><td>1</td><td>48</td><td>49</td><td>3</td><td>319</td><td>322</td><td>0</td><td>19</td><td>19</td></tr> <tr><td>9時～10時</td><td>4</td><td>135</td><td>139</td><td>10</td><td>259</td><td>269</td><td>2</td><td>46</td><td>48</td><td>2</td><td>50</td><td>52</td><td>4</td><td>343</td><td>347</td><td>0</td><td>22</td><td>22</td></tr> <tr><td>10時～11時</td><td>2</td><td>194</td><td>196</td><td>14</td><td>329</td><td>343</td><td>2</td><td>42</td><td>44</td><td>2</td><td>73</td><td>75</td><td>2</td><td>422</td><td>424</td><td>0</td><td>24</td><td>24</td></tr> <tr><td>11時～12時</td><td>2</td><td>262</td><td>264</td><td>7</td><td>376</td><td>383</td><td>0</td><td>70</td><td>70</td><td>2</td><td>92</td><td>94</td><td>1</td><td>414</td><td>415</td><td>0</td><td>32</td><td>32</td></tr> <tr><td>12時～13時</td><td>1</td><td>229</td><td>230</td><td>9</td><td>366</td><td>375</td><td>3</td><td>66</td><td>69</td><td>1</td><td>99</td><td>100</td><td>2</td><td>409</td><td>411</td><td>1</td><td>44</td><td>45</td></tr> <tr><td>13時～14時</td><td>2</td><td>171</td><td>173</td><td>6</td><td>381</td><td>387</td><td>5</td><td>57</td><td>62</td><td>2</td><td>108</td><td>110</td><td>3</td><td>405</td><td>408</td><td>2</td><td>60</td><td>62</td></tr> <tr><td>14時～15時</td><td>0</td><td>218</td><td>218</td><td>15</td><td>345</td><td>360</td><td>3</td><td>67</td><td>70</td><td>1</td><td>87</td><td>88</td><td>6</td><td>417</td><td>423</td><td>1</td><td>41</td><td>42</td></tr> <tr><td>15時～16時</td><td>1</td><td>240</td><td>241</td><td>8</td><td>366</td><td>374</td><td>4</td><td>71</td><td>75</td><td>1</td><td>69</td><td>70</td><td>2</td><td>380</td><td>382</td><td>1</td><td>50</td><td>51</td></tr> <tr><td>16時～17時</td><td>2</td><td>175</td><td>177</td><td>7</td><td>375</td><td>382</td><td>3</td><td>58</td><td>61</td><td>0</td><td>61</td><td>61</td><td>3</td><td>371</td><td>374</td><td>1</td><td>42</td><td>43</td></tr> <tr><td>17時～18時</td><td>4</td><td>202</td><td>206</td><td>6</td><td>362</td><td>368</td><td>6</td><td>47</td><td>53</td><td>1</td><td>70</td><td>71</td><td>4</td><td>372</td><td>376</td><td>0</td><td>32</td><td>32</td></tr> <tr><td>18時～19時</td><td>3</td><td>185</td><td>188</td><td>5</td><td>321</td><td>326</td><td>4</td><td>44</td><td>48</td><td>1</td><td>76</td><td>77</td><td>3</td><td>341</td><td>344</td><td>0</td><td>28</td><td>28</td></tr> <tr><td>19時～20時</td><td>3</td><td>169</td><td>172</td><td>6</td><td>278</td><td>284</td><td>3</td><td>50</td><td>53</td><td>1</td><td>69</td><td>70</td><td>2</td><td>306</td><td>308</td><td>1</td><td>21</td><td>22</td></tr> <tr><td>20時～21時</td><td>4</td><td>144</td><td>148</td><td>3</td><td>240</td><td>243</td><td>3</td><td>39</td><td>42</td><td>2</td><td>53</td><td>55</td><td>2</td><td>282</td><td>284</td><td>1</td><td>19</td><td>20</td></tr> <tr><td>21時～22時</td><td>2</td><td>129</td><td>131</td><td>4</td><td>222</td><td>226</td><td>2</td><td>34</td><td>36</td><td>0</td><td>49</td><td>49</td><td>3</td><td>261</td><td>264</td><td>0</td><td>15</td><td>15</td></tr> <tr><td>22時～23時</td><td>1</td><td>97</td><td>98</td><td>3</td><td>157</td><td>160</td><td>2</td><td>22</td><td>24</td><td>1</td><td>37</td><td>38</td><td>2</td><td>222</td><td>224</td><td>0</td><td>11</td><td>11</td></tr> <tr><td>計</td><td>34</td><td>2,669</td><td>2,703</td><td>116</td><td>4,610</td><td>4,726</td><td>43</td><td>752</td><td>795</td><td>18</td><td>1,041</td><td>1,059</td><td>42</td><td>5,264</td><td>5,306</td><td>8</td><td>460</td><td>468</td></tr> </table>																		8時～9時	3	119	122	13	233	246	1	39	40	1	48	49	3	319	322	0	19	19	9時～10時	4	135	139	10	259	269	2	46	48	2	50	52	4	343	347	0	22	22	10時～11時	2	194	196	14	329	343	2	42	44	2	73	75	2	422	424	0	24	24	11時～12時	2	262	264	7	376	383	0	70	70	2	92	94	1	414	415	0	32	32	12時～13時	1	229	230	9	366	375	3	66	69	1	99	100	2	409	411	1	44	45	13時～14時	2	171	173	6	381	387	5	57	62	2	108	110	3	405	408	2	60	62	14時～15時	0	218	218	15	345	360	3	67	70	1	87	88	6	417	423	1	41	42	15時～16時	1	240	241	8	366	374	4	71	75	1	69	70	2	380	382	1	50	51	16時～17時	2	175	177	7	375	382	3	58	61	0	61	61	3	371	374	1	42	43	17時～18時	4	202	206	6	362	368	6	47	53	1	70	71	4	372	376	0	32	32	18時～19時	3	185	188	5	321	326	4	44	48	1	76	77	3	341	344	0	28	28	19時～20時	3	169	172	6	278	284	3	50	53	1	69	70	2	306	308	1	21	22	20時～21時	4	144	148	3	240	243	3	39	42	2	53	55	2	282	284	1	19	20	21時～22時	2	129	131	4	222	226	2	34	36	0	49	49	3	261	264	0	15	15	22時～23時	1	97	98	3	157	160	2	22	24	1	37	38	2	222	224	0	11	11	計	34	2,669	2,703	116	4,610	4,726	43	752	795	18	1,041	1,059	42	5,264	5,306	8	460	468
8時～9時	3	119	122	13	233	246	1	39	40	1	48	49	3	319	322	0	19	19																																																																																																																																																																																																																																																																																																																
9時～10時	4	135	139	10	259	269	2	46	48	2	50	52	4	343	347	0	22	22																																																																																																																																																																																																																																																																																																																
10時～11時	2	194	196	14	329	343	2	42	44	2	73	75	2	422	424	0	24	24																																																																																																																																																																																																																																																																																																																
11時～12時	2	262	264	7	376	383	0	70	70	2	92	94	1	414	415	0	32	32																																																																																																																																																																																																																																																																																																																
12時～13時	1	229	230	9	366	375	3	66	69	1	99	100	2	409	411	1	44	45																																																																																																																																																																																																																																																																																																																
13時～14時	2	171	173	6	381	387	5	57	62	2	108	110	3	405	408	2	60	62																																																																																																																																																																																																																																																																																																																
14時～15時	0	218	218	15	345	360	3	67	70	1	87	88	6	417	423	1	41	42																																																																																																																																																																																																																																																																																																																
15時～16時	1	240	241	8	366	374	4	71	75	1	69	70	2	380	382	1	50	51																																																																																																																																																																																																																																																																																																																
16時～17時	2	175	177	7	375	382	3	58	61	0	61	61	3	371	374	1	42	43																																																																																																																																																																																																																																																																																																																
17時～18時	4	202	206	6	362	368	6	47	53	1	70	71	4	372	376	0	32	32																																																																																																																																																																																																																																																																																																																
18時～19時	3	185	188	5	321	326	4	44	48	1	76	77	3	341	344	0	28	28																																																																																																																																																																																																																																																																																																																
19時～20時	3	169	172	6	278	284	3	50	53	1	69	70	2	306	308	1	21	22																																																																																																																																																																																																																																																																																																																
20時～21時	4	144	148	3	240	243	3	39	42	2	53	55	2	282	284	1	19	20																																																																																																																																																																																																																																																																																																																
21時～22時	2	129	131	4	222	226	2	34	36	0	49	49	3	261	264	0	15	15																																																																																																																																																																																																																																																																																																																
22時～23時	1	97	98	3	157	160	2	22	24	1	37	38	2	222	224	0	11	11																																																																																																																																																																																																																																																																																																																
計	34	2,669	2,703	116	4,610	4,726	43	752	795	18	1,041	1,059	42	5,264	5,306	8	460	468																																																																																																																																																																																																																																																																																																																

調査方向区分	全方向																																																																																			
車両区分	大型車	小型車	合計	大型車混入率(%)																																																																																
時刻	<table border="1"> <tr><td>8時～9時</td><td>37</td><td>1,670</td><td>1,707</td><td>2.2</td></tr> <tr><td>9時～10時</td><td>41</td><td>1,817</td><td>1,858</td><td>2.2</td></tr> <tr><td>10時～11時</td><td>43</td><td>2,174</td><td>2,217</td><td>1.9</td></tr> <tr><td>11時～12時</td><td>28</td><td>2,328</td><td>2,356</td><td>1.2</td></tr> <tr><td>12時～13時</td><td>36</td><td>2,285</td><td>2,321</td><td>1.6</td></tr> <tr><td>13時～14時</td><td>46</td><td>2,254</td><td>2,300</td><td>2.0</td></tr> <tr><td>14時～15時</td><td>43</td><td>2,187</td><td>2,230</td><td>1.9</td></tr> <tr><td>15時～16時</td><td>34</td><td>2,189</td><td>2,223</td><td>1.5</td></tr> <tr><td>16時～17時</td><td>33</td><td>1,993</td><td>2,026</td><td>1.6</td></tr> <tr><td>17時～18時</td><td>34</td><td>2,054</td><td>2,088</td><td>1.6</td></tr> <tr><td>18時～19時</td><td>26</td><td>1,909</td><td>1,935</td><td>1.3</td></tr> <tr><td>19時～20時</td><td>25</td><td>1,715</td><td>1,740</td><td>1.4</td></tr> <tr><td>20時～21時</td><td>24</td><td>1,453</td><td>1,477</td><td>1.6</td></tr> <tr><td>21時～22時</td><td>21</td><td>1,275</td><td>1,296</td><td>1.6</td></tr> <tr><td>22時～23時</td><td>16</td><td>1,000</td><td>1,016</td><td>1.6</td></tr> <tr><td>計</td><td>487</td><td>28,303</td><td>28,790</td><td>1.7</td></tr> </table>				8時～9時	37	1,670	1,707	2.2	9時～10時	41	1,817	1,858	2.2	10時～11時	43	2,174	2,217	1.9	11時～12時	28	2,328	2,356	1.2	12時～13時	36	2,285	2,321	1.6	13時～14時	46	2,254	2,300	2.0	14時～15時	43	2,187	2,230	1.9	15時～16時	34	2,189	2,223	1.5	16時～17時	33	1,993	2,026	1.6	17時～18時	34	2,054	2,088	1.6	18時～19時	26	1,909	1,935	1.3	19時～20時	25	1,715	1,740	1.4	20時～21時	24	1,453	1,477	1.6	21時～22時	21	1,275	1,296	1.6	22時～23時	16	1,000	1,016	1.6	計	487	28,303	28,790	1.7
8時～9時	37	1,670	1,707	2.2																																																																																
9時～10時	41	1,817	1,858	2.2																																																																																
10時～11時	43	2,174	2,217	1.9																																																																																
11時～12時	28	2,328	2,356	1.2																																																																																
12時～13時	36	2,285	2,321	1.6																																																																																
13時～14時	46	2,254	2,300	2.0																																																																																
14時～15時	43	2,187	2,230	1.9																																																																																
15時～16時	34	2,189	2,223	1.5																																																																																
16時～17時	33	1,993	2,026	1.6																																																																																
17時～18時	34	2,054	2,088	1.6																																																																																
18時～19時	26	1,909	1,935	1.3																																																																																
19時～20時	25	1,715	1,740	1.4																																																																																
20時～21時	24	1,453	1,477	1.6																																																																																
21時～22時	21	1,275	1,296	1.6																																																																																
22時～23時	16	1,000	1,016	1.6																																																																																
計	487	28,303	28,790	1.7																																																																																

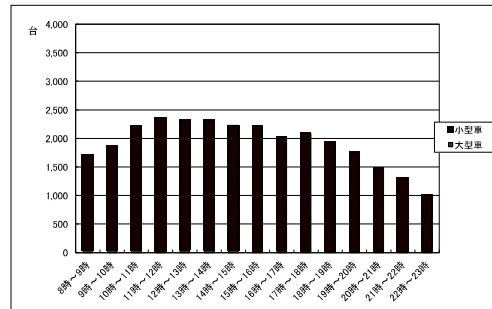

地点	No.4																																																																																																																																																																																																																																																																																																																																	
調査日	令和7年10月26日(日)																																																																																																																																																																																																																																																																																																																																	
天候	曇り																																																																																																																																																																																																																																																																																																																																	
概要	当交差点の交通量ピークは14時～15時であった。																																																																																																																																																																																																																																																																																																																																	
調査方向区分	AからDへ右折 方向1			AからCへ直進 方向2			AからBへ左折 方向3			BからAへ右折 方向4			BからDへ直進 方向5			BからCへ左折 方向6																																																																																																																																																																																																																																																																																																																		
車両区分	大型車	小型車	合計	大型車	小型車	合計	大型車	小型車	合計	大型車	小型車	合計	大型車	小型車	合計	大型車	小型車	合計																																																																																																																																																																																																																																																																																																																
時刻	<table border="1"> <tr><td>8時～9時</td><td>0</td><td>48</td><td>48</td><td>13</td><td>422</td><td>435</td><td>1</td><td>44</td><td>45</td><td>0</td><td>54</td><td>54</td><td>1</td><td>155</td><td>156</td><td>0</td><td>39</td><td>39</td></tr> <tr><td>9時～10時</td><td>0</td><td>62</td><td>62</td><td>15</td><td>440</td><td>455</td><td>1</td><td>53</td><td>54</td><td>1</td><td>68</td><td>69</td><td>2</td><td>169</td><td>171</td><td>0</td><td>43</td><td>43</td></tr> <tr><td>10時～11時</td><td>0</td><td>77</td><td>77</td><td>11</td><td>413</td><td>424</td><td>2</td><td>60</td><td>62</td><td>2</td><td>66</td><td>68</td><td>1</td><td>183</td><td>184</td><td>1</td><td>54</td><td>55</td></tr> <tr><td>11時～12時</td><td>0</td><td>84</td><td>84</td><td>14</td><td>388</td><td>402</td><td>1</td><td>75</td><td>76</td><td>1</td><td>73</td><td>74</td><td>3</td><td>291</td><td>294</td><td>0</td><td>63</td><td>63</td></tr> <tr><td>12時～13時</td><td>1</td><td>75</td><td>76</td><td>16</td><td>335</td><td>351</td><td>2</td><td>78</td><td>80</td><td>1</td><td>82</td><td>83</td><td>2</td><td>223</td><td>225</td><td>0</td><td>85</td><td>85</td></tr> <tr><td>13時～14時</td><td>0</td><td>69</td><td>69</td><td>13</td><td>392</td><td>405</td><td>2</td><td>89</td><td>91</td><td>2</td><td>74</td><td>76</td><td>2</td><td>234</td><td>236</td><td>1</td><td>79</td><td>80</td></tr> <tr><td>14時～15時</td><td>0</td><td>90</td><td>90</td><td>12</td><td>454</td><td>466</td><td>3</td><td>85</td><td>88</td><td>1</td><td>62</td><td>63</td><td>3</td><td>240</td><td>243</td><td>1</td><td>86</td><td>87</td></tr> <tr><td>15時～16時</td><td>2</td><td>82</td><td>84</td><td>8</td><td>359</td><td>367</td><td>1</td><td>80</td><td>81</td><td>2</td><td>81</td><td>83</td><td>2</td><td>232</td><td>234</td><td>0</td><td>77</td><td>77</td></tr> <tr><td>16時～17時</td><td>0</td><td>72</td><td>72</td><td>5</td><td>382</td><td>387</td><td>2</td><td>72</td><td>74</td><td>2</td><td>76</td><td>78</td><td>1</td><td>200</td><td>201</td><td>2</td><td>82</td><td>84</td></tr> <tr><td>17時～18時</td><td>1</td><td>76</td><td>77</td><td>5</td><td>359</td><td>364</td><td>1</td><td>81</td><td>82</td><td>1</td><td>66</td><td>67</td><td>1</td><td>196</td><td>197</td><td>1</td><td>88</td><td>89</td></tr> <tr><td>18時～19時</td><td>0</td><td>68</td><td>68</td><td>6</td><td>295</td><td>301</td><td>1</td><td>73</td><td>74</td><td>0</td><td>60</td><td>60</td><td>2</td><td>179</td><td>181</td><td>0</td><td>79</td><td>79</td></tr> <tr><td>19時～20時</td><td>0</td><td>62</td><td>62</td><td>5</td><td>248</td><td>253</td><td>2</td><td>64</td><td>66</td><td>1</td><td>52</td><td>53</td><td>1</td><td>156</td><td>157</td><td>1</td><td>58</td><td>59</td></tr> <tr><td>20時～21時</td><td>1</td><td>59</td><td>60</td><td>4</td><td>198</td><td>202</td><td>1</td><td>58</td><td>59</td><td>1</td><td>47</td><td>48</td><td>1</td><td>132</td><td>133</td><td>0</td><td>55</td><td>55</td></tr> <tr><td>21時～22時</td><td>0</td><td>45</td><td>45</td><td>3</td><td>148</td><td>151</td><td>0</td><td>43</td><td>43</td><td>0</td><td>44</td><td>44</td><td>2</td><td>113</td><td>115</td><td>0</td><td>42</td><td>42</td></tr> <tr><td>22時～23時</td><td>0</td><td>30</td><td>30</td><td>2</td><td>90</td><td>92</td><td>0</td><td>35</td><td>35</td><td>0</td><td>32</td><td>32</td><td>1</td><td>99</td><td>100</td><td>1</td><td>36</td><td>37</td></tr> <tr><td>計</td><td>5</td><td>999</td><td>1,004</td><td>132</td><td>4,923</td><td>5,055</td><td>20</td><td>990</td><td>1,010</td><td>15</td><td>937</td><td>952</td><td>25</td><td>2,802</td><td>2,827</td><td>8</td><td>966</td><td>974</td></tr> </table>																		8時～9時	0	48	48	13	422	435	1	44	45	0	54	54	1	155	156	0	39	39	9時～10時	0	62	62	15	440	455	1	53	54	1	68	69	2	169	171	0	43	43	10時～11時	0	77	77	11	413	424	2	60	62	2	66	68	1	183	184	1	54	55	11時～12時	0	84	84	14	388	402	1	75	76	1	73	74	3	291	294	0	63	63	12時～13時	1	75	76	16	335	351	2	78	80	1	82	83	2	223	225	0	85	85	13時～14時	0	69	69	13	392	405	2	89	91	2	74	76	2	234	236	1	79	80	14時～15時	0	90	90	12	454	466	3	85	88	1	62	63	3	240	243	1	86	87	15時～16時	2	82	84	8	359	367	1	80	81	2	81	83	2	232	234	0	77	77	16時～17時	0	72	72	5	382	387	2	72	74	2	76	78	1	200	201	2	82	84	17時～18時	1	76	77	5	359	364	1	81	82	1	66	67	1	196	197	1	88	89	18時～19時	0	68	68	6	295	301	1	73	74	0	60	60	2	179	181	0	79	79	19時～20時	0	62	62	5	248	253	2	64	66	1	52	53	1	156	157	1	58	59	20時～21時	1	59	60	4	198	202	1	58	59	1	47	48	1	132	133	0	55	55	21時～22時	0	45	45	3	148	151	0	43	43	0	44	44	2	113	115	0	42	42	22時～23時	0	30	30	2	90	92	0	35	35	0	32	32	1	99	100	1	36	37	計	5	999	1,004	132	4,923	5,055	20	990	1,010	15	937	952	25	2,802	2,827	8	966	974
8時～9時	0	48	48	13	422	435	1	44	45	0	54	54	1	155	156	0	39	39																																																																																																																																																																																																																																																																																																																
9時～10時	0	62	62	15	440	455	1	53	54	1	68	69	2	169	171	0	43	43																																																																																																																																																																																																																																																																																																																
10時～11時	0	77	77	11	413	424	2	60	62	2	66	68	1	183	184	1	54	55																																																																																																																																																																																																																																																																																																																
11時～12時	0	84	84	14	388	402	1	75	76	1	73	74	3	291	294	0	63	63																																																																																																																																																																																																																																																																																																																
12時～13時	1	75	76	16	335	351	2	78	80	1	82	83	2	223	225	0	85	85																																																																																																																																																																																																																																																																																																																
13時～14時	0	69	69	13	392	405	2	89	91	2	74	76	2	234	236	1	79	80																																																																																																																																																																																																																																																																																																																
14時～15時	0	90	90	12	454	466	3	85	88	1	62	63	3	240	243	1	86	87																																																																																																																																																																																																																																																																																																																
15時～16時	2	82	84	8	359	367	1	80	81	2	81	83	2	232	234	0	77	77																																																																																																																																																																																																																																																																																																																
16時～17時	0	72	72	5	382	387	2	72	74	2	76	78	1	200	201	2	82	84																																																																																																																																																																																																																																																																																																																
17時～18時	1	76	77	5	359	364	1	81	82	1	66	67	1	196	197	1	88	89																																																																																																																																																																																																																																																																																																																
18時～19時	0	68	68	6	295	301	1	73	74	0	60	60	2	179	181	0	79	79																																																																																																																																																																																																																																																																																																																
19時～20時	0	62	62	5	248	253	2	64	66	1	52	53	1	156	157	1	58	59																																																																																																																																																																																																																																																																																																																
20時～21時	1	59	60	4	198	202	1	58	59	1	47	48	1	132	133	0	55	55																																																																																																																																																																																																																																																																																																																
21時～22時	0	45	45	3	148	151	0	43	43	0	44	44	2	113	115	0	42	42																																																																																																																																																																																																																																																																																																																
22時～23時	0	30	30	2	90	92	0	35	35	0	32	32	1	99	100	1	36	37																																																																																																																																																																																																																																																																																																																
計	5	999	1,004	132	4,923	5,055	20	990	1,010	15	937	952	25	2,802	2,827	8	966	974																																																																																																																																																																																																																																																																																																																

調査方向区分	CからBへ右折 方向7			CからAへ直進 方向8			CからDへ左折 方向9			DからCへ右折 方向10			DからBへ直進 方向11			DからAへ左折 方向12																																																																																																																																																																																																																																																																																																																		
車両区分	大型車	小型車	合計	大型車	小型車	合計	大型車	小型車	合計	大型車	小型車	合計	大型車	小型車	合計	大型車	小型車	合計																																																																																																																																																																																																																																																																																																																
時刻	<table border="1"> <tr><td>8時～9時</td><td>2</td><td>38</td><td>40</td><td>5</td><td>429</td><td>434</td><td>1</td><td>48</td><td>49</td><td>1</td><td>38</td><td>39</td><td>3</td><td>110</td><td>113</td><td>1</td><td>40</td><td>41</td></tr> <tr><td>9時～10時</td><td>1</td><td>49</td><td>50</td><td>7</td><td>460</td><td>467</td><td>2</td><td>35</td><td>37</td><td>2</td><td>47</td><td>49</td><td>2</td><td>152</td><td>154</td><td>0</td><td>52</td><td>52</td></tr> <tr><td>10時～11時</td><td>1</td><td>47</td><td>48</td><td>6</td><td>422</td><td>428</td><td>1</td><td>39</td><td>40</td><td>1</td><td>55</td><td>56</td><td>3</td><td>139</td><td>142</td><td>1</td><td>49</td><td>50</td></tr> <tr><td>11時～12時</td><td>2</td><td>55</td><td>57</td><td>5</td><td>371</td><td>376</td><td>2</td><td>33</td><td>35</td><td>0</td><td>60</td><td>60</td><td>2</td><td>166</td><td>168</td><td>2</td><td>55</td><td>57</td></tr> <tr><td>12時～13時</td><td>2</td><td>67</td><td>69</td><td>5</td><td>352</td><td>357</td><td>2</td><td>43</td><td>45</td><td>1</td><td>65</td><td>66</td><td>1</td><td>183</td><td>184</td><td>1</td><td>60</td><td>61</td></tr> <tr><td>13時～14時</td><td>1</td><td>61</td><td>62</td><td>7</td><td>413</td><td>420</td><td>1</td><td>54</td><td>55</td><td>0</td><td>54</td><td>54</td><td>1</td><td>190</td><td>191</td><td>1</td><td>71</td><td>72</td></tr> <tr><td>14時～15時</td><td>0</td><td>70</td><td>70</td><td>6</td><td>508</td><td>514</td><td>0</td><td>41</td><td>41</td><td>1</td><td>61</td><td>62</td><td>2</td><td>204</td><td>206</td><td>2</td><td>74</td><td>76</td></tr> <tr><td>15時～16時</td><td>1</td><td>77</td><td>78</td><td>3</td><td>453</td><td>456</td><td>1</td><td>35</td><td>36</td><td>0</td><td>59</td><td>59</td><td>1</td><td>155</td><td>156</td><td>0</td><td>59</td><td>59</td></tr> <tr><td>16時～17時</td><td>0</td><td>81</td><td>81</td><td>4</td><td>348</td><td>352</td><td>1</td><td>40</td><td>41</td><td>1</td><td>48</td><td>49</td><td>0</td><td>142</td><td>142</td><td>1</td><td>60</td><td>61</td></tr> <tr><td>17時～18時</td><td>1</td><td>72</td><td>73</td><td>6</td><td>413</td><td>419</td><td>1</td><td>44</td><td>45</td><td>0</td><td>33</td><td>33</td><td>1</td><td>151</td><td>152</td><td>1</td><td>45</td><td>46</td></tr> <tr><td>18時～19時</td><td>0</td><td>69</td><td>69</td><td>4</td><td>373</td><td>377</td><td>0</td><td>47</td><td>47</td><td>0</td><td>40</td><td>40</td><td>0</td><td>137</td><td>137</td><td>0</td><td>48</td><td>48</td></tr> <tr><td>19時～20時</td><td>0</td><td>62</td><td>62</td><td>4</td><td>339</td><td>343</td><td>1</td><td>39</td><td>40</td><td>0</td><td>37</td><td>37</td><td>0</td><td>110</td><td>110</td><td>1</td><td>44</td><td>45</td></tr> <tr><td>20時～21時</td><td>1</td><td>48</td><td>49</td><td>3</td><td>194</td><td>197</td><td>1</td><td>32</td><td>33</td><td>0</td><td>33</td><td>33</td><td>1</td><td>99</td><td>100</td><td>0</td><td>37</td><td>37</td></tr> <tr><td>21時～22時</td><td>0</td><td>34</td><td>34</td><td>2</td><td>166</td><td>168</td><td>0</td><td>25</td><td>25</td><td>1</td><td>27</td><td>28</td><td>0</td><td>84</td><td>84</td><td>0</td><td>31</td><td>31</td></tr> <tr><td>22時～23時</td><td>1</td><td>33</td><td>34</td><td>3</td><td>110</td><td>113</td><td>0</td><td>22</td><td>22</td><td>0</td><td>22</td><td>22</td><td>0</td><td>55</td><td>55</td><td>0</td><td>20</td><td>20</td></tr> <tr><td>計</td><td>13</td><td>863</td><td>876</td><td>70</td><td>5,351</td><td>5,421</td><td>14</td><td>577</td><td>591</td><td>8</td><td>679</td><td>687</td><td>17</td><td>2,077</td><td>2,094</td><td>11</td><td>745</td><td>758</td></tr> </table>																		8時～9時	2	38	40	5	429	434	1	48	49	1	38	39	3	110	113	1	40	41	9時～10時	1	49	50	7	460	467	2	35	37	2	47	49	2	152	154	0	52	52	10時～11時	1	47	48	6	422	428	1	39	40	1	55	56	3	139	142	1	49	50	11時～12時	2	55	57	5	371	376	2	33	35	0	60	60	2	166	168	2	55	57	12時～13時	2	67	69	5	352	357	2	43	45	1	65	66	1	183	184	1	60	61	13時～14時	1	61	62	7	413	420	1	54	55	0	54	54	1	190	191	1	71	72	14時～15時	0	70	70	6	508	514	0	41	41	1	61	62	2	204	206	2	74	76	15時～16時	1	77	78	3	453	456	1	35	36	0	59	59	1	155	156	0	59	59	16時～17時	0	81	81	4	348	352	1	40	41	1	48	49	0	142	142	1	60	61	17時～18時	1	72	73	6	413	419	1	44	45	0	33	33	1	151	152	1	45	46	18時～19時	0	69	69	4	373	377	0	47	47	0	40	40	0	137	137	0	48	48	19時～20時	0	62	62	4	339	343	1	39	40	0	37	37	0	110	110	1	44	45	20時～21時	1	48	49	3	194	197	1	32	33	0	33	33	1	99	100	0	37	37	21時～22時	0	34	34	2	166	168	0	25	25	1	27	28	0	84	84	0	31	31	22時～23時	1	33	34	3	110	113	0	22	22	0	22	22	0	55	55	0	20	20	計	13	863	876	70	5,351	5,421	14	577	591	8	679	687	17	2,077	2,094	11	745	758
8時～9時	2	38	40	5	429	434	1	48	49	1	38	39	3	110	113	1	40	41																																																																																																																																																																																																																																																																																																																
9時～10時	1	49	50	7	460	467	2	35	37	2	47	49	2	152	154	0	52	52																																																																																																																																																																																																																																																																																																																
10時～11時	1	47	48	6	422	428	1	39	40	1	55	56	3	139	142	1	49	50																																																																																																																																																																																																																																																																																																																
11時～12時	2	55	57	5	371	376	2	33	35	0	60	60	2	166	168	2	55	57																																																																																																																																																																																																																																																																																																																
12時～13時	2	67	69	5	352	357	2	43	45	1	65	66	1	183	184	1	60	61																																																																																																																																																																																																																																																																																																																
13時～14時	1	61	62	7	413	420	1	54	55	0	54	54	1	190	191	1	71	72																																																																																																																																																																																																																																																																																																																
14時～15時	0	70	70	6	508	514	0	41	41	1	61	62	2	204	206	2	74	76																																																																																																																																																																																																																																																																																																																
15時～16時	1	77	78	3	453	456	1	35	36	0	59	59	1	155	156	0	59	59																																																																																																																																																																																																																																																																																																																
16時～17時	0	81	81	4	348	352	1	40	41	1	48	49	0	142	142	1	60	61																																																																																																																																																																																																																																																																																																																
17時～18時	1	72	73	6	413	419	1	44	45	0	33	33	1	151	152	1	45	46																																																																																																																																																																																																																																																																																																																
18時～19時	0	69	69	4	373	377	0	47	47	0	40	40	0	137	137	0	48	48																																																																																																																																																																																																																																																																																																																
19時～20時	0	62	62	4	339	343	1	39	40	0	37	37	0	110	110	1	44	45																																																																																																																																																																																																																																																																																																																
20時～21時	1	48	49	3	194	197	1	32	33	0	33	33	1	99	100	0	37	37																																																																																																																																																																																																																																																																																																																
21時～22時	0	34	34	2	166	168	0	25	25	1	27	28	0	84	84	0	31	31																																																																																																																																																																																																																																																																																																																
22時～23時	1	33	34	3	110	113	0	22	22	0	22	22	0	55	55	0	20	20																																																																																																																																																																																																																																																																																																																
計	13	863	876	70	5,351	5,421	14	577	591	8	679	687	17	2,077	2,094	11	745	758																																																																																																																																																																																																																																																																																																																

調査方向区分	全方向																																																																																			
車両区分	大型車	小型車	合計	大型車混入率(%)																																																																																
時刻	<table border="1"> <tr><td>8時～9時</td><td>28</td><td>1,465</td><td>1,493</td><td>1.9</td></tr> <tr><td>9時～10時</td><td>33</td><td>1,630</td><td>1,663</td><td>2.0</td></tr> <tr><td>10時～11時</td><td>30</td><td>1,604</td><td>1,634</td><td>1.8</td></tr> <tr><td>11時～12時</td><td>32</td><td>1,714</td><td>1,746</td><td>1.8</td></tr> <tr><td>12時～13時</td><td>34</td><td>1,648</td><td>1,682</td><td>2.0</td></tr> <tr><td>13時～14時</td><td>31</td><td>1,780</td><td>1,811</td><td>1.7</td></tr> <tr><td>14時～15時</td><td>31</td><td>1,975</td><td>2,006</td><td>1.5</td></tr> <tr><td>15時～16時</td><td>21</td><td>1,749</td><td>1,770</td><td>1.2</td></tr> <tr><td>16時～17時</td><td>19</td><td>1,603</td><td>1,622</td><td>1.2</td></tr> <tr><td>17時～18時</td><td>20</td><td>1,624</td><td>1,644</td><td>1.2</td></tr> <tr><td>18時～19時</td><td>13</td><td>1,468</td><td>1,481</td><td>0.9</td></tr> <tr><td>19時～20時</td><td>16</td><td>1,271</td><td>1,287</td><td>1.2</td></tr> <tr><td>20時～21時</td><td>14</td><td>992</td><td>1,006</td><td>1.4</td></tr> <tr><td>21時～22時</td><td>8</td><td>802</td><td>810</td><td>1.0</td></tr> <tr><td>22時～23時</td><td>8</td><td>584</td><td>592</td><td>1.4</td></tr> <tr><td>計</td><td>338</td><td>21,909</td><td>22,247</td><td>1.5</td></tr> </table>				8時～9時	28	1,465	1,493	1.9	9時～10時	33	1,630	1,663	2.0	10時～11時	30	1,604	1,634	1.8	11時～12時	32	1,714	1,746	1.8	12時～13時	34	1,648	1,682	2.0	13時～14時	31	1,780	1,811	1.7	14時～15時	31	1,975	2,006	1.5	15時～16時	21	1,749	1,770	1.2	16時～17時	19	1,603	1,622	1.2	17時～18時	20	1,624	1,644	1.2	18時～19時	13	1,468	1,481	0.9	19時～20時	16	1,271	1,287	1.2	20時～21時	14	992	1,006	1.4	21時～22時	8	802	810	1.0	22時～23時	8	584	592	1.4	計	338	21,909	22,247	1.5
8時～9時	28	1,465	1,493	1.9																																																																																
9時～10時	33	1,630	1,663	2.0																																																																																
10時～11時	30	1,604	1,634	1.8																																																																																
11時～12時	32	1,714	1,746	1.8																																																																																
12時～13時	34	1,648	1,682	2.0																																																																																
13時～14時	31	1,780	1,811	1.7																																																																																
14時～15時	31	1,975	2,006	1.5																																																																																
15時～16時	21	1,749	1,770	1.2																																																																																
16時～17時	19	1,603	1,622	1.2																																																																																
17時～18時	20	1,624	1,644	1.2																																																																																
18時～19時	13	1,468	1,481	0.9																																																																																
19時～20時	16	1,271	1,287	1.2																																																																																
20時～21時	14	992	1,006	1.4																																																																																
21時～22時	8	802	810	1.0																																																																																
22時～23時	8	584	592	1.4																																																																																
計	338	21,909	22,247	1.5																																																																																

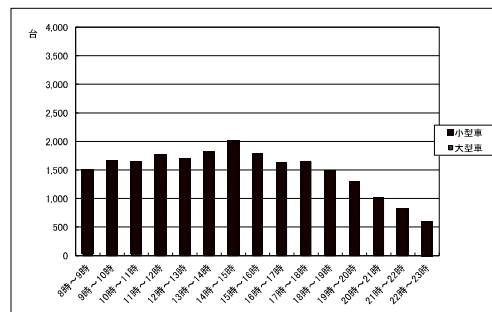

地点	No.5																																																																																																																																																																																																																																																																																																																																	
調査日	令和7年10月26日(日)																																																																																																																																																																																																																																																																																																																																	
天気	曇り																																																																																																																																																																																																																																																																																																																																	
概要	当交差点の交通量ピークは15時～16時であった。																																																																																																																																																																																																																																																																																																																																	
調査方向区分	AからDへ右折 方向1			AからCへ直進 方向2			AからBへ左折 方向3			BからAへ右折 方向4			BからDへ直進 方向5			BからCへ左折 方向6																																																																																																																																																																																																																																																																																																																		
車両区分	大型車	小型車	合計	大型車	小型車	合計	大型車	小型車	合計	大型車	小型車	合計	大型車	小型車	合計	大型車	小型車	合計																																																																																																																																																																																																																																																																																																																
時刻	<table border="1"> <tr><td>8時～9時</td><td>1</td><td>66</td><td>67</td><td>2</td><td>124</td><td>126</td><td>0</td><td>8</td><td>8</td><td>0</td><td>21</td><td>21</td><td>2</td><td>146</td><td>148</td><td>0</td><td>27</td><td>27</td></tr> <tr><td>9時～10時</td><td>0</td><td>85</td><td>85</td><td>1</td><td>211</td><td>212</td><td>1</td><td>7</td><td>8</td><td>1</td><td>22</td><td>23</td><td>1</td><td>161</td><td>162</td><td>1</td><td>31</td><td>32</td></tr> <tr><td>10時～11時</td><td>0</td><td>91</td><td>91</td><td>1</td><td>253</td><td>254</td><td>2</td><td>10</td><td>12</td><td>0</td><td>37</td><td>37</td><td>0</td><td>188</td><td>188</td><td>2</td><td>39</td><td>41</td></tr> <tr><td>11時～12時</td><td>1</td><td>107</td><td>108</td><td>2</td><td>248</td><td>250</td><td>1</td><td>14</td><td>15</td><td>1</td><td>36</td><td>37</td><td>1</td><td>198</td><td>199</td><td>1</td><td>30</td><td>31</td></tr> <tr><td>12時～13時</td><td>0</td><td>85</td><td>85</td><td>1</td><td>222</td><td>223</td><td>0</td><td>9</td><td>9</td><td>0</td><td>30</td><td>30</td><td>2</td><td>203</td><td>205</td><td>0</td><td>41</td><td>41</td></tr> <tr><td>13時～14時</td><td>2</td><td>66</td><td>68</td><td>1</td><td>239</td><td>240</td><td>1</td><td>16</td><td>17</td><td>1</td><td>32</td><td>33</td><td>0</td><td>220</td><td>220</td><td>0</td><td>46</td><td>46</td></tr> <tr><td>14時～15時</td><td>0</td><td>98</td><td>98</td><td>1</td><td>232</td><td>233</td><td>1</td><td>26</td><td>27</td><td>1</td><td>34</td><td>35</td><td>0</td><td>231</td><td>231</td><td>2</td><td>38</td><td>40</td></tr> <tr><td>15時～16時</td><td>1</td><td>90</td><td>91</td><td>1</td><td>241</td><td>242</td><td>1</td><td>21</td><td>22</td><td>0</td><td>30</td><td>30</td><td>2</td><td>221</td><td>223</td><td>0</td><td>33</td><td>33</td></tr> <tr><td>16時～17時</td><td>1</td><td>94</td><td>95</td><td>1</td><td>220</td><td>221</td><td>0</td><td>20</td><td>20</td><td>1</td><td>28</td><td>29</td><td>1</td><td>184</td><td>185</td><td>0</td><td>29</td><td>29</td></tr> <tr><td>17時～18時</td><td>0</td><td>75</td><td>75</td><td>2</td><td>194</td><td>196</td><td>1</td><td>13</td><td>14</td><td>0</td><td>25</td><td>25</td><td>0</td><td>173</td><td>173</td><td>1</td><td>23</td><td>24</td></tr> <tr><td>18時～19時</td><td>0</td><td>66</td><td>66</td><td>1</td><td>201</td><td>202</td><td>1</td><td>9</td><td>10</td><td>0</td><td>21</td><td>21</td><td>1</td><td>160</td><td>161</td><td>0</td><td>21</td><td>21</td></tr> <tr><td>19時～20時</td><td>1</td><td>59</td><td>60</td><td>0</td><td>188</td><td>188</td><td>0</td><td>12</td><td>12</td><td>1</td><td>19</td><td>20</td><td>0</td><td>136</td><td>136</td><td>1</td><td>30</td><td>31</td></tr> <tr><td>20時～21時</td><td>0</td><td>48</td><td>48</td><td>1</td><td>163</td><td>164</td><td>1</td><td>8</td><td>9</td><td>0</td><td>15</td><td>15</td><td>0</td><td>134</td><td>134</td><td>1</td><td>29</td><td>30</td></tr> <tr><td>21時～22時</td><td>0</td><td>44</td><td>44</td><td>1</td><td>138</td><td>139</td><td>0</td><td>6</td><td>6</td><td>0</td><td>14</td><td>14</td><td>0</td><td>110</td><td>110</td><td>0</td><td>21</td><td>21</td></tr> <tr><td>22時～23時</td><td>0</td><td>30</td><td>30</td><td>0</td><td>114</td><td>114</td><td>0</td><td>5</td><td>5</td><td>0</td><td>32</td><td>32</td><td>1</td><td>76</td><td>77</td><td>0</td><td>14</td><td>14</td></tr> <tr><td>計</td><td>7</td><td>1,104</td><td>1,111</td><td>16</td><td>2,988</td><td>3,004</td><td>10</td><td>184</td><td>194</td><td>6</td><td>396</td><td>402</td><td>11</td><td>2,541</td><td>2,552</td><td>9</td><td>452</td><td>461</td></tr> </table>																		8時～9時	1	66	67	2	124	126	0	8	8	0	21	21	2	146	148	0	27	27	9時～10時	0	85	85	1	211	212	1	7	8	1	22	23	1	161	162	1	31	32	10時～11時	0	91	91	1	253	254	2	10	12	0	37	37	0	188	188	2	39	41	11時～12時	1	107	108	2	248	250	1	14	15	1	36	37	1	198	199	1	30	31	12時～13時	0	85	85	1	222	223	0	9	9	0	30	30	2	203	205	0	41	41	13時～14時	2	66	68	1	239	240	1	16	17	1	32	33	0	220	220	0	46	46	14時～15時	0	98	98	1	232	233	1	26	27	1	34	35	0	231	231	2	38	40	15時～16時	1	90	91	1	241	242	1	21	22	0	30	30	2	221	223	0	33	33	16時～17時	1	94	95	1	220	221	0	20	20	1	28	29	1	184	185	0	29	29	17時～18時	0	75	75	2	194	196	1	13	14	0	25	25	0	173	173	1	23	24	18時～19時	0	66	66	1	201	202	1	9	10	0	21	21	1	160	161	0	21	21	19時～20時	1	59	60	0	188	188	0	12	12	1	19	20	0	136	136	1	30	31	20時～21時	0	48	48	1	163	164	1	8	9	0	15	15	0	134	134	1	29	30	21時～22時	0	44	44	1	138	139	0	6	6	0	14	14	0	110	110	0	21	21	22時～23時	0	30	30	0	114	114	0	5	5	0	32	32	1	76	77	0	14	14	計	7	1,104	1,111	16	2,988	3,004	10	184	194	6	396	402	11	2,541	2,552	9	452	461
8時～9時	1	66	67	2	124	126	0	8	8	0	21	21	2	146	148	0	27	27																																																																																																																																																																																																																																																																																																																
9時～10時	0	85	85	1	211	212	1	7	8	1	22	23	1	161	162	1	31	32																																																																																																																																																																																																																																																																																																																
10時～11時	0	91	91	1	253	254	2	10	12	0	37	37	0	188	188	2	39	41																																																																																																																																																																																																																																																																																																																
11時～12時	1	107	108	2	248	250	1	14	15	1	36	37	1	198	199	1	30	31																																																																																																																																																																																																																																																																																																																
12時～13時	0	85	85	1	222	223	0	9	9	0	30	30	2	203	205	0	41	41																																																																																																																																																																																																																																																																																																																
13時～14時	2	66	68	1	239	240	1	16	17	1	32	33	0	220	220	0	46	46																																																																																																																																																																																																																																																																																																																
14時～15時	0	98	98	1	232	233	1	26	27	1	34	35	0	231	231	2	38	40																																																																																																																																																																																																																																																																																																																
15時～16時	1	90	91	1	241	242	1	21	22	0	30	30	2	221	223	0	33	33																																																																																																																																																																																																																																																																																																																
16時～17時	1	94	95	1	220	221	0	20	20	1	28	29	1	184	185	0	29	29																																																																																																																																																																																																																																																																																																																
17時～18時	0	75	75	2	194	196	1	13	14	0	25	25	0	173	173	1	23	24																																																																																																																																																																																																																																																																																																																
18時～19時	0	66	66	1	201	202	1	9	10	0	21	21	1	160	161	0	21	21																																																																																																																																																																																																																																																																																																																
19時～20時	1	59	60	0	188	188	0	12	12	1	19	20	0	136	136	1	30	31																																																																																																																																																																																																																																																																																																																
20時～21時	0	48	48	1	163	164	1	8	9	0	15	15	0	134	134	1	29	30																																																																																																																																																																																																																																																																																																																
21時～22時	0	44	44	1	138	139	0	6	6	0	14	14	0	110	110	0	21	21																																																																																																																																																																																																																																																																																																																
22時～23時	0	30	30	0	114	114	0	5	5	0	32	32	1	76	77	0	14	14																																																																																																																																																																																																																																																																																																																
計	7	1,104	1,111	16	2,988	3,004	10	184	194	6	396	402	11	2,541	2,552	9	452	461																																																																																																																																																																																																																																																																																																																

調査方向区分	CからBへ右折 方向7			CからAへ直進 方向8			CからDへ左折 方向9			DからCへ右折 方向10			DからBへ直進 方向11			DからAへ左折 方向12																																																																																																																																																																																																																																																																																																																		
車両区分	大型車	小型車	合計	大型車	小型車	合計	大型車	小型車	合計	大型車	小型車	合計	大型車	小型車	合計	大型車	小型車	合計																																																																																																																																																																																																																																																																																																																
時刻	<table border="1"> <tr><td>8時～9時</td><td>1</td><td>30</td><td>31</td><td>1</td><td>188</td><td>189</td><td>1</td><td>37</td><td>38</td><td>1</td><td>47</td><td>48</td><td>4</td><td>143</td><td>147</td><td>0</td><td>36</td><td>36</td></tr> <tr><td>9時～10時</td><td>1</td><td>32</td><td>33</td><td>2</td><td>204</td><td>206</td><td>2</td><td>32</td><td>34</td><td>0</td><td>33</td><td>33</td><td>5</td><td>166</td><td>171</td><td>0</td><td>39</td><td>39</td></tr> <tr><td>10時～11時</td><td>0</td><td>44</td><td>44</td><td>1</td><td>244</td><td>245</td><td>3</td><td>41</td><td>44</td><td>1</td><td>28</td><td>29</td><td>3</td><td>179</td><td>182</td><td>1</td><td>41</td><td>42</td></tr> <tr><td>11時～12時</td><td>2</td><td>51</td><td>53</td><td>2</td><td>239</td><td>241</td><td>2</td><td>47</td><td>49</td><td>2</td><td>56</td><td>58</td><td>4</td><td>196</td><td>200</td><td>1</td><td>54</td><td>55</td></tr> <tr><td>12時～13時</td><td>1</td><td>43</td><td>44</td><td>3</td><td>221</td><td>224</td><td>1</td><td>45</td><td>46</td><td>1</td><td>60</td><td>61</td><td>5</td><td>239</td><td>244</td><td>0</td><td>60</td><td>60</td></tr> <tr><td>13時～14時</td><td>0</td><td>47</td><td>47</td><td>2</td><td>204</td><td>206</td><td>1</td><td>39</td><td>40</td><td>0</td><td>63</td><td>63</td><td>3</td><td>202</td><td>205</td><td>0</td><td>64</td><td>64</td></tr> <tr><td>14時～15時</td><td>0</td><td>40</td><td>40</td><td>4</td><td>117</td><td>121</td><td>1</td><td>50</td><td>51</td><td>0</td><td>70</td><td>70</td><td>4</td><td>291</td><td>295</td><td>2</td><td>55</td><td>57</td></tr> <tr><td>15時～16時</td><td>2</td><td>32</td><td>34</td><td>3</td><td>209</td><td>212</td><td>3</td><td>66</td><td>69</td><td>2</td><td>69</td><td>71</td><td>6</td><td>249</td><td>255</td><td>0</td><td>69</td><td>69</td></tr> <tr><td>16時～17時</td><td>0</td><td>28</td><td>28</td><td>1</td><td>194</td><td>195</td><td>2</td><td>70</td><td>72</td><td>1</td><td>84</td><td>85</td><td>2</td><td>262</td><td>264</td><td>1</td><td>80</td><td>81</td></tr> <tr><td>17時～18時</td><td>0</td><td>41</td><td>41</td><td>2</td><td>183</td><td>185</td><td>1</td><td>59</td><td>60</td><td>0</td><td>71</td><td>71</td><td>3</td><td>233</td><td>236</td><td>0</td><td>74</td><td>74</td></tr> <tr><td>18時～19時</td><td>0</td><td>38</td><td>38</td><td>3</td><td>201</td><td>204</td><td>0</td><td>53</td><td>53</td><td>1</td><td>56</td><td>57</td><td>2</td><td>195</td><td>197</td><td>1</td><td>59</td><td>60</td></tr> <tr><td>19時～20時</td><td>1</td><td>22</td><td>23</td><td>2</td><td>174</td><td>176</td><td>1</td><td>38</td><td>39</td><td>0</td><td>49</td><td>49</td><td>4</td><td>178</td><td>182</td><td>0</td><td>43</td><td>43</td></tr> <tr><td>20時～21時</td><td>0</td><td>30</td><td>30</td><td>1</td><td>155</td><td>156</td><td>1</td><td>40</td><td>41</td><td>0</td><td>44</td><td>44</td><td>3</td><td>140</td><td>143</td><td>0</td><td>37</td><td>37</td></tr> <tr><td>21時～22時</td><td>0</td><td>27</td><td>27</td><td>2</td><td>139</td><td>141</td><td>1</td><td>33</td><td>34</td><td>1</td><td>48</td><td>49</td><td>2</td><td>104</td><td>106</td><td>1</td><td>31</td><td>32</td></tr> <tr><td>22時～23時</td><td>1</td><td>14</td><td>15</td><td>2</td><td>78</td><td>80</td><td>0</td><td>27</td><td>27</td><td>0</td><td>30</td><td>30</td><td>1</td><td>70</td><td>71</td><td>0</td><td>26</td><td>26</td></tr> <tr><td>計</td><td>9</td><td>519</td><td>528</td><td>31</td><td>2,750</td><td>2,781</td><td>20</td><td>677</td><td>697</td><td>10</td><td>808</td><td>818</td><td>51</td><td>2,847</td><td>2,898</td><td>7</td><td>768</td><td>775</td></tr> </table>																		8時～9時	1	30	31	1	188	189	1	37	38	1	47	48	4	143	147	0	36	36	9時～10時	1	32	33	2	204	206	2	32	34	0	33	33	5	166	171	0	39	39	10時～11時	0	44	44	1	244	245	3	41	44	1	28	29	3	179	182	1	41	42	11時～12時	2	51	53	2	239	241	2	47	49	2	56	58	4	196	200	1	54	55	12時～13時	1	43	44	3	221	224	1	45	46	1	60	61	5	239	244	0	60	60	13時～14時	0	47	47	2	204	206	1	39	40	0	63	63	3	202	205	0	64	64	14時～15時	0	40	40	4	117	121	1	50	51	0	70	70	4	291	295	2	55	57	15時～16時	2	32	34	3	209	212	3	66	69	2	69	71	6	249	255	0	69	69	16時～17時	0	28	28	1	194	195	2	70	72	1	84	85	2	262	264	1	80	81	17時～18時	0	41	41	2	183	185	1	59	60	0	71	71	3	233	236	0	74	74	18時～19時	0	38	38	3	201	204	0	53	53	1	56	57	2	195	197	1	59	60	19時～20時	1	22	23	2	174	176	1	38	39	0	49	49	4	178	182	0	43	43	20時～21時	0	30	30	1	155	156	1	40	41	0	44	44	3	140	143	0	37	37	21時～22時	0	27	27	2	139	141	1	33	34	1	48	49	2	104	106	1	31	32	22時～23時	1	14	15	2	78	80	0	27	27	0	30	30	1	70	71	0	26	26	計	9	519	528	31	2,750	2,781	20	677	697	10	808	818	51	2,847	2,898	7	768	775
8時～9時	1	30	31	1	188	189	1	37	38	1	47	48	4	143	147	0	36	36																																																																																																																																																																																																																																																																																																																
9時～10時	1	32	33	2	204	206	2	32	34	0	33	33	5	166	171	0	39	39																																																																																																																																																																																																																																																																																																																
10時～11時	0	44	44	1	244	245	3	41	44	1	28	29	3	179	182	1	41	42																																																																																																																																																																																																																																																																																																																
11時～12時	2	51	53	2	239	241	2	47	49	2	56	58	4	196	200	1	54	55																																																																																																																																																																																																																																																																																																																
12時～13時	1	43	44	3	221	224	1	45	46	1	60	61	5	239	244	0	60	60																																																																																																																																																																																																																																																																																																																
13時～14時	0	47	47	2	204	206	1	39	40	0	63	63	3	202	205	0	64	64																																																																																																																																																																																																																																																																																																																
14時～15時	0	40	40	4	117	121	1	50	51	0	70	70	4	291	295	2	55	57																																																																																																																																																																																																																																																																																																																
15時～16時	2	32	34	3	209	212	3	66	69	2	69	71	6	249	255	0	69	69																																																																																																																																																																																																																																																																																																																
16時～17時	0	28	28	1	194	195	2	70	72	1	84	85	2	262	264	1	80	81																																																																																																																																																																																																																																																																																																																
17時～18時	0	41	41	2	183	185	1	59	60	0	71	71	3	233	236	0	74	74																																																																																																																																																																																																																																																																																																																
18時～19時	0	38	38	3	201	204	0	53	53	1	56	57	2	195	197	1	59	60																																																																																																																																																																																																																																																																																																																
19時～20時	1	22	23	2	174	176	1	38	39	0	49	49	4	178	182	0	43	43																																																																																																																																																																																																																																																																																																																
20時～21時	0	30	30	1	155	156	1	40	41	0	44	44	3	140	143	0	37	37																																																																																																																																																																																																																																																																																																																
21時～22時	0	27	27	2	139	141	1	33	34	1	48	49	2	104	106	1	31	32																																																																																																																																																																																																																																																																																																																
22時～23時	1	14	15	2	78	80	0	27	27	0	30	30	1	70	71	0	26	26																																																																																																																																																																																																																																																																																																																
計	9	519	528	31	2,750	2,781	20	677	697	10	808	818	51	2,847	2,898	7	768	775																																																																																																																																																																																																																																																																																																																

調査方向区分	全方向																																																																																			
車両区分	大型車	小型車	合計	大型車混入率(%)																																																																																
時刻	<table border="1"> <tr><td>8時～9時</td><td>13</td><td>873</td><td>886</td><td>1.5</td></tr> <tr><td>9時～10時</td><td>15</td><td>1,023</td><td>1,038</td><td>1.4</td></tr> <tr><td>10時～11時</td><td>14</td><td>1,195</td><td>1,209</td><td>1.2</td></tr> <tr><td>11時～12時</td><td>20</td><td>1,276</td><td>1,296</td><td>1.5</td></tr> <tr><td>12時～13時</td><td>14</td><td>1,258</td><td>1,272</td><td>1.1</td></tr> <tr><td>13時～14時</td><td>11</td><td>1,238</td><td>1,249</td><td>0.9</td></tr> <tr><td>14時～15時</td><td>16</td><td>1,282</td><td>1,298</td><td>1.2</td></tr> <tr><td>15時～16時</td><td>21</td><td>1,330</td><td>1,351</td><td>1.6</td></tr> <tr><td>16時～17時</td><td>11</td><td>1,293</td><td>1,304</td><td>0.8</td></tr> <tr><td>17時～18時</td><td>10</td><td>1,164</td><td>1,174</td><td>0.9</td></tr> <tr><td>18時～19時</td><td>10</td><td>1,080</td><td>1,090</td><td>0.9</td></tr> <tr><td>19時～20時</td><td>11</td><td>948</td><td>959</td><td>1.1</td></tr> <tr><td>20時～21時</td><td>8</td><td>843</td><td>851</td><td>0.9</td></tr> <tr><td>21時～22時</td><td>8</td><td>715</td><td>723</td><td>1.1</td></tr> <tr><td>22時～23時</td><td>5</td><td>516</td><td>521</td><td>1.0</td></tr> <tr><td>計</td><td>187</td><td>16,034</td><td>16,221</td><td>1.2</td></tr> </table>				8時～9時	13	873	886	1.5	9時～10時	15	1,023	1,038	1.4	10時～11時	14	1,195	1,209	1.2	11時～12時	20	1,276	1,296	1.5	12時～13時	14	1,258	1,272	1.1	13時～14時	11	1,238	1,249	0.9	14時～15時	16	1,282	1,298	1.2	15時～16時	21	1,330	1,351	1.6	16時～17時	11	1,293	1,304	0.8	17時～18時	10	1,164	1,174	0.9	18時～19時	10	1,080	1,090	0.9	19時～20時	11	948	959	1.1	20時～21時	8	843	851	0.9	21時～22時	8	715	723	1.1	22時～23時	5	516	521	1.0	計	187	16,034	16,221	1.2
8時～9時	13	873	886	1.5																																																																																
9時～10時	15	1,023	1,038	1.4																																																																																
10時～11時	14	1,195	1,209	1.2																																																																																
11時～12時	20	1,276	1,296	1.5																																																																																
12時～13時	14	1,258	1,272	1.1																																																																																
13時～14時	11	1,238	1,249	0.9																																																																																
14時～15時	16	1,282	1,298	1.2																																																																																
15時～16時	21	1,330	1,351	1.6																																																																																
16時～17時	11	1,293	1,304	0.8																																																																																
17時～18時	10	1,164	1,174	0.9																																																																																
18時～19時	10	1,080	1,090	0.9																																																																																
19時～20時	11	948	959	1.1																																																																																
20時～21時	8	843	851	0.9																																																																																
21時～22時	8	715	723	1.1																																																																																
22時～23時	5	516	521	1.0																																																																																
計	187	16,034	16,221	1.2																																																																																

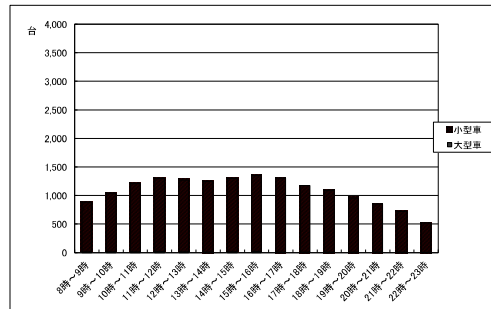

地点	No.1																																																																																																																																																																																																																																																																																																																																	
調査日	令和7年10月27日(月)																																																																																																																																																																																																																																																																																																																																	
天候	曇り																																																																																																																																																																																																																																																																																																																																	
概要	当交差点の交通量ピークは8時～9時であった。																																																																																																																																																																																																																																																																																																																																	
調査方向区分	AからDへ右折 方向1			AからCへ直進 方向2			AからBへ左折 方向3			BからAへ右折 方向4			BからDへ直進 方向5			BからCへ左折 方向6																																																																																																																																																																																																																																																																																																																		
車両区分	大型車	小型車	合計	大型車	小型車	合計	大型車	小型車	合計	大型車	小型車	合計	大型車	小型車	合計	大型車	小型車	合計																																																																																																																																																																																																																																																																																																																
時刻	<table border="1"> <tr><td>8時～9時</td><td>91</td><td>329</td><td>420</td><td>0</td><td>0</td><td>0</td><td>5</td><td>8</td><td>13</td><td>0</td><td>0</td><td>0</td><td>32</td><td>313</td><td>345</td><td>0</td><td>0</td><td>0</td></tr> <tr><td>9時～10時</td><td>84</td><td>209</td><td>293</td><td>0</td><td>0</td><td>0</td><td>5</td><td>17</td><td>22</td><td>0</td><td>0</td><td>0</td><td>35</td><td>277</td><td>312</td><td>0</td><td>0</td><td>0</td></tr> <tr><td>10時～11時</td><td>101</td><td>188</td><td>289</td><td>0</td><td>0</td><td>0</td><td>2</td><td>10</td><td>12</td><td>0</td><td>0</td><td>0</td><td>29</td><td>356</td><td>385</td><td>0</td><td>0</td><td>0</td></tr> <tr><td>11時～12時</td><td>73</td><td>151</td><td>224</td><td>0</td><td>0</td><td>0</td><td>6</td><td>12</td><td>18</td><td>0</td><td>0</td><td>0</td><td>20</td><td>340</td><td>360</td><td>0</td><td>0</td><td>0</td></tr> <tr><td>12時～13時</td><td>80</td><td>143</td><td>223</td><td>0</td><td>0</td><td>0</td><td>2</td><td>7</td><td>9</td><td>0</td><td>0</td><td>0</td><td>31</td><td>348</td><td>379</td><td>0</td><td>0</td><td>0</td></tr> <tr><td>13時～14時</td><td>66</td><td>132</td><td>198</td><td>0</td><td>0</td><td>0</td><td>2</td><td>6</td><td>8</td><td>0</td><td>0</td><td>0</td><td>28</td><td>354</td><td>382</td><td>0</td><td>0</td><td>0</td></tr> <tr><td>14時～15時</td><td>50</td><td>116</td><td>166</td><td>0</td><td>0</td><td>0</td><td>3</td><td>5</td><td>8</td><td>0</td><td>0</td><td>0</td><td>33</td><td>274</td><td>307</td><td>0</td><td>0</td><td>0</td></tr> <tr><td>15時～16時</td><td>57</td><td>168</td><td>225</td><td>0</td><td>0</td><td>0</td><td>6</td><td>11</td><td>17</td><td>0</td><td>0</td><td>0</td><td>26</td><td>319</td><td>345</td><td>0</td><td>0</td><td>0</td></tr> <tr><td>16時～17時</td><td>42</td><td>174</td><td>216</td><td>0</td><td>0</td><td>0</td><td>4</td><td>10</td><td>14</td><td>0</td><td>0</td><td>0</td><td>24</td><td>352</td><td>376</td><td>0</td><td>0</td><td>0</td></tr> <tr><td>17時～18時</td><td>48</td><td>155</td><td>203</td><td>0</td><td>0</td><td>0</td><td>4</td><td>8</td><td>12</td><td>0</td><td>0</td><td>0</td><td>22</td><td>327</td><td>349</td><td>0</td><td>0</td><td>0</td></tr> <tr><td>18時～19時</td><td>40</td><td>130</td><td>170</td><td>0</td><td>0</td><td>0</td><td>5</td><td>10</td><td>15</td><td>0</td><td>0</td><td>0</td><td>18</td><td>310</td><td>328</td><td>0</td><td>0</td><td>0</td></tr> <tr><td>19時～20時</td><td>36</td><td>111</td><td>147</td><td>0</td><td>0</td><td>0</td><td>3</td><td>9</td><td>12</td><td>0</td><td>0</td><td>0</td><td>14</td><td>277</td><td>291</td><td>0</td><td>0</td><td>0</td></tr> <tr><td>20時～21時</td><td>31</td><td>90</td><td>121</td><td>0</td><td>0</td><td>0</td><td>2</td><td>9</td><td>11</td><td>0</td><td>0</td><td>0</td><td>13</td><td>248</td><td>261</td><td>0</td><td>0</td><td>0</td></tr> <tr><td>21時～22時</td><td>27</td><td>74</td><td>101</td><td>0</td><td>0</td><td>0</td><td>1</td><td>8</td><td>9</td><td>0</td><td>0</td><td>0</td><td>11</td><td>231</td><td>242</td><td>0</td><td>0</td><td>0</td></tr> <tr><td>22時～23時</td><td>22</td><td>59</td><td>81</td><td>0</td><td>0</td><td>0</td><td>1</td><td>5</td><td>6</td><td>0</td><td>0</td><td>0</td><td>9</td><td>201</td><td>210</td><td>0</td><td>0</td><td>0</td></tr> <tr><td>計</td><td>848</td><td>2,229</td><td>3,077</td><td>0</td><td>0</td><td>0</td><td>51</td><td>135</td><td>186</td><td>0</td><td>0</td><td>0</td><td>345</td><td>4,527</td><td>4,872</td><td>0</td><td>0</td><td>0</td></tr> </table>																		8時～9時	91	329	420	0	0	0	5	8	13	0	0	0	32	313	345	0	0	0	9時～10時	84	209	293	0	0	0	5	17	22	0	0	0	35	277	312	0	0	0	10時～11時	101	188	289	0	0	0	2	10	12	0	0	0	29	356	385	0	0	0	11時～12時	73	151	224	0	0	0	6	12	18	0	0	0	20	340	360	0	0	0	12時～13時	80	143	223	0	0	0	2	7	9	0	0	0	31	348	379	0	0	0	13時～14時	66	132	198	0	0	0	2	6	8	0	0	0	28	354	382	0	0	0	14時～15時	50	116	166	0	0	0	3	5	8	0	0	0	33	274	307	0	0	0	15時～16時	57	168	225	0	0	0	6	11	17	0	0	0	26	319	345	0	0	0	16時～17時	42	174	216	0	0	0	4	10	14	0	0	0	24	352	376	0	0	0	17時～18時	48	155	203	0	0	0	4	8	12	0	0	0	22	327	349	0	0	0	18時～19時	40	130	170	0	0	0	5	10	15	0	0	0	18	310	328	0	0	0	19時～20時	36	111	147	0	0	0	3	9	12	0	0	0	14	277	291	0	0	0	20時～21時	31	90	121	0	0	0	2	9	11	0	0	0	13	248	261	0	0	0	21時～22時	27	74	101	0	0	0	1	8	9	0	0	0	11	231	242	0	0	0	22時～23時	22	59	81	0	0	0	1	5	6	0	0	0	9	201	210	0	0	0	計	848	2,229	3,077	0	0	0	51	135	186	0	0	0	345	4,527	4,872	0	0	0
8時～9時	91	329	420	0	0	0	5	8	13	0	0	0	32	313	345	0	0	0																																																																																																																																																																																																																																																																																																																
9時～10時	84	209	293	0	0	0	5	17	22	0	0	0	35	277	312	0	0	0																																																																																																																																																																																																																																																																																																																
10時～11時	101	188	289	0	0	0	2	10	12	0	0	0	29	356	385	0	0	0																																																																																																																																																																																																																																																																																																																
11時～12時	73	151	224	0	0	0	6	12	18	0	0	0	20	340	360	0	0	0																																																																																																																																																																																																																																																																																																																
12時～13時	80	143	223	0	0	0	2	7	9	0	0	0	31	348	379	0	0	0																																																																																																																																																																																																																																																																																																																
13時～14時	66	132	198	0	0	0	2	6	8	0	0	0	28	354	382	0	0	0																																																																																																																																																																																																																																																																																																																
14時～15時	50	116	166	0	0	0	3	5	8	0	0	0	33	274	307	0	0	0																																																																																																																																																																																																																																																																																																																
15時～16時	57	168	225	0	0	0	6	11	17	0	0	0	26	319	345	0	0	0																																																																																																																																																																																																																																																																																																																
16時～17時	42	174	216	0	0	0	4	10	14	0	0	0	24	352	376	0	0	0																																																																																																																																																																																																																																																																																																																
17時～18時	48	155	203	0	0	0	4	8	12	0	0	0	22	327	349	0	0	0																																																																																																																																																																																																																																																																																																																
18時～19時	40	130	170	0	0	0	5	10	15	0	0	0	18	310	328	0	0	0																																																																																																																																																																																																																																																																																																																
19時～20時	36	111	147	0	0	0	3	9	12	0	0	0	14	277	291	0	0	0																																																																																																																																																																																																																																																																																																																
20時～21時	31	90	121	0	0	0	2	9	11	0	0	0	13	248	261	0	0	0																																																																																																																																																																																																																																																																																																																
21時～22時	27	74	101	0	0	0	1	8	9	0	0	0	11	231	242	0	0	0																																																																																																																																																																																																																																																																																																																
22時～23時	22	59	81	0	0	0	1	5	6	0	0	0	9	201	210	0	0	0																																																																																																																																																																																																																																																																																																																
計	848	2,229	3,077	0	0	0	51	135	186	0	0	0	345	4,527	4,872	0	0	0																																																																																																																																																																																																																																																																																																																

調査方向区分	CからBへ右折 方向7			CからAへ直進 方向8			CからDへ左折 方向9			DからCへ右折 方向10			DからBへ直進 方向11			DからAへ左折 方向12																																																																																																																																																																																																																																																																																																																		
車両区分	大型車	小型車	合計	大型車	小型車	合計	大型車	小型車	合計	大型車	小型車	合計	大型車	小型車	合計	大型車	小型車	合計																																																																																																																																																																																																																																																																																																																
時刻	<table border="1"> <tr><td>8時～9時</td><td>0</td><td>0</td><td>0</td><td>0</td><td>0</td><td>0</td><td>0</td><td>0</td><td>0</td><td>0</td><td>0</td><td>0</td><td>24</td><td>392</td><td>416</td><td>64</td><td>276</td><td>340</td></tr> <tr><td>9時～10時</td><td>0</td><td>0</td><td>0</td><td>0</td><td>0</td><td>0</td><td>0</td><td>0</td><td>0</td><td>0</td><td>0</td><td>0</td><td>24</td><td>360</td><td>384</td><td>85</td><td>156</td><td>241</td></tr> <tr><td>10時～11時</td><td>0</td><td>0</td><td>0</td><td>0</td><td>0</td><td>0</td><td>0</td><td>0</td><td>0</td><td>0</td><td>0</td><td>0</td><td>36</td><td>318</td><td>354</td><td>48</td><td>128</td><td>176</td></tr> <tr><td>11時～12時</td><td>0</td><td>0</td><td>0</td><td>0</td><td>0</td><td>0</td><td>0</td><td>0</td><td>0</td><td>0</td><td>0</td><td>0</td><td>31</td><td>330</td><td>361</td><td>66</td><td>149</td><td>215</td></tr> <tr><td>12時～13時</td><td>0</td><td>0</td><td>0</td><td>0</td><td>0</td><td>0</td><td>0</td><td>0</td><td>0</td><td>0</td><td>0</td><td>0</td><td>28</td><td>357</td><td>385</td><td>53</td><td>110</td><td>163</td></tr> <tr><td>13時～14時</td><td>0</td><td>0</td><td>0</td><td>0</td><td>0</td><td>0</td><td>0</td><td>0</td><td>0</td><td>0</td><td>0</td><td>0</td><td>33</td><td>381</td><td>414</td><td>45</td><td>87</td><td>132</td></tr> <tr><td>14時～15時</td><td>0</td><td>0</td><td>0</td><td>0</td><td>0</td><td>0</td><td>0</td><td>0</td><td>0</td><td>0</td><td>0</td><td>0</td><td>28</td><td>352</td><td>380</td><td>52</td><td>118</td><td>170</td></tr> <tr><td>15時～16時</td><td>0</td><td>0</td><td>0</td><td>0</td><td>0</td><td>0</td><td>0</td><td>0</td><td>0</td><td>0</td><td>0</td><td>0</td><td>31</td><td>345</td><td>376</td><td>35</td><td>145</td><td>180</td></tr> <tr><td>16時～17時</td><td>0</td><td>0</td><td>0</td><td>0</td><td>0</td><td>0</td><td>0</td><td>0</td><td>0</td><td>0</td><td>0</td><td>0</td><td>22</td><td>332</td><td>354</td><td>56</td><td>180</td><td>236</td></tr> <tr><td>17時～18時</td><td>0</td><td>0</td><td>0</td><td>0</td><td>0</td><td>0</td><td>0</td><td>0</td><td>0</td><td>0</td><td>0</td><td>0</td><td>28</td><td>285</td><td>313</td><td>49</td><td>168</td><td>217</td></tr> <tr><td>18時～19時</td><td>0</td><td>0</td><td>0</td><td>0</td><td>0</td><td>0</td><td>0</td><td>0</td><td>0</td><td>0</td><td>0</td><td>0</td><td>20</td><td>271</td><td>291</td><td>41</td><td>136</td><td>177</td></tr> <tr><td>19時～20時</td><td>0</td><td>0</td><td>0</td><td>0</td><td>0</td><td>0</td><td>0</td><td>0</td><td>0</td><td>0</td><td>0</td><td>0</td><td>17</td><td>232</td><td>249</td><td>35</td><td>119</td><td>154</td></tr> <tr><td>20時～21時</td><td>0</td><td>0</td><td>0</td><td>0</td><td>0</td><td>0</td><td>0</td><td>0</td><td>0</td><td>0</td><td>0</td><td>0</td><td>13</td><td>217</td><td>230</td><td>31</td><td>80</td><td>111</td></tr> <tr><td>21時～22時</td><td>0</td><td>0</td><td>0</td><td>0</td><td>0</td><td>0</td><td>0</td><td>0</td><td>0</td><td>0</td><td>0</td><td>0</td><td>11</td><td>178</td><td>189</td><td>24</td><td>73</td><td>97</td></tr> <tr><td>22時～23時</td><td>0</td><td>0</td><td>0</td><td>0</td><td>0</td><td>0</td><td>0</td><td>0</td><td>0</td><td>0</td><td>0</td><td>0</td><td>9</td><td>154</td><td>163</td><td>22</td><td>55</td><td>77</td></tr> <tr><td>計</td><td>0</td><td>0</td><td>0</td><td>0</td><td>0</td><td>0</td><td>0</td><td>0</td><td>0</td><td>0</td><td>0</td><td>0</td><td>355</td><td>4,504</td><td>4,859</td><td>706</td><td>1,980</td><td>2,686</td></tr> </table>																		8時～9時	0	0	0	0	0	0	0	0	0	0	0	0	24	392	416	64	276	340	9時～10時	0	0	0	0	0	0	0	0	0	0	0	0	24	360	384	85	156	241	10時～11時	0	0	0	0	0	0	0	0	0	0	0	0	36	318	354	48	128	176	11時～12時	0	0	0	0	0	0	0	0	0	0	0	0	31	330	361	66	149	215	12時～13時	0	0	0	0	0	0	0	0	0	0	0	0	28	357	385	53	110	163	13時～14時	0	0	0	0	0	0	0	0	0	0	0	0	33	381	414	45	87	132	14時～15時	0	0	0	0	0	0	0	0	0	0	0	0	28	352	380	52	118	170	15時～16時	0	0	0	0	0	0	0	0	0	0	0	0	31	345	376	35	145	180	16時～17時	0	0	0	0	0	0	0	0	0	0	0	0	22	332	354	56	180	236	17時～18時	0	0	0	0	0	0	0	0	0	0	0	0	28	285	313	49	168	217	18時～19時	0	0	0	0	0	0	0	0	0	0	0	0	20	271	291	41	136	177	19時～20時	0	0	0	0	0	0	0	0	0	0	0	0	17	232	249	35	119	154	20時～21時	0	0	0	0	0	0	0	0	0	0	0	0	13	217	230	31	80	111	21時～22時	0	0	0	0	0	0	0	0	0	0	0	0	11	178	189	24	73	97	22時～23時	0	0	0	0	0	0	0	0	0	0	0	0	9	154	163	22	55	77	計	0	0	0	0	0	0	0	0	0	0	0	0	355	4,504	4,859	706	1,980	2,686
8時～9時	0	0	0	0	0	0	0	0	0	0	0	0	24	392	416	64	276	340																																																																																																																																																																																																																																																																																																																
9時～10時	0	0	0	0	0	0	0	0	0	0	0	0	24	360	384	85	156	241																																																																																																																																																																																																																																																																																																																
10時～11時	0	0	0	0	0	0	0	0	0	0	0	0	36	318	354	48	128	176																																																																																																																																																																																																																																																																																																																
11時～12時	0	0	0	0	0	0	0	0	0	0	0	0	31	330	361	66	149	215																																																																																																																																																																																																																																																																																																																
12時～13時	0	0	0	0	0	0	0	0	0	0	0	0	28	357	385	53	110	163																																																																																																																																																																																																																																																																																																																
13時～14時	0	0	0	0	0	0	0	0	0	0	0	0	33	381	414	45	87	132																																																																																																																																																																																																																																																																																																																
14時～15時	0	0	0	0	0	0	0	0	0	0	0	0	28	352	380	52	118	170																																																																																																																																																																																																																																																																																																																
15時～16時	0	0	0	0	0	0	0	0	0	0	0	0	31	345	376	35	145	180																																																																																																																																																																																																																																																																																																																
16時～17時	0	0	0	0	0	0	0	0	0	0	0	0	22	332	354	56	180	236																																																																																																																																																																																																																																																																																																																
17時～18時	0	0	0	0	0	0	0	0	0	0	0	0	28	285	313	49	168	217																																																																																																																																																																																																																																																																																																																
18時～19時	0	0	0	0	0	0	0	0	0	0	0	0	20	271	291	41	136	177																																																																																																																																																																																																																																																																																																																
19時～20時	0	0	0	0	0	0	0	0	0	0	0	0	17	232	249	35	119	154																																																																																																																																																																																																																																																																																																																
20時～21時	0	0	0	0	0	0	0	0	0	0	0	0	13	217	230	31	80	111																																																																																																																																																																																																																																																																																																																
21時～22時	0	0	0	0	0	0	0	0	0	0	0	0	11	178	189	24	73	97																																																																																																																																																																																																																																																																																																																
22時～23時	0	0	0	0	0	0	0	0	0	0	0	0	9	154	163	22	55	77																																																																																																																																																																																																																																																																																																																
計	0	0	0	0	0	0	0	0	0	0	0	0	355	4,504	4,859	706	1,980	2,686																																																																																																																																																																																																																																																																																																																

調査方向区分	全方向																																																																																			
車両区分	大型車	小型車	合計	大型車混入率(%)																																																																																
時刻	<table border="1"> <tr><td>8時～9時</td><td>216</td><td>1,318</td><td>1,534</td><td>14.1</td></tr> <tr><td>9時～10時</td><td>233</td><td>1,019</td><td>1,252</td><td>18.6</td></tr> <tr><td>10時～11時</td><td>216</td><td>1,000</td><td>1,216</td><td>17.8</td></tr> <tr><td>11時～12時</td><td>196</td><td>982</td><td>1,178</td><td>16.6</td></tr> <tr><td>12時～13時</td><td>194</td><td>965</td><td>1,159</td><td>16.7</td></tr> <tr><td>13時～14時</td><td>174</td><td>960</td><td>1,134</td><td>15.3</td></tr> <tr><td>14時～15時</td><td>166</td><td>865</td><td>1,031</td><td>16.1</td></tr> <tr><td>15時～16時</td><td>155</td><td>988</td><td>1,143</td><td>13.6</td></tr> <tr><td>16時～17時</td><td>148</td><td>1,048</td><td>1,196</td><td>12.4</td></tr> <tr><td>17時～18時</td><td>151</td><td>943</td><td>1,094</td><td>13.8</td></tr> <tr><td>18時～19時</td><td>124</td><td>857</td><td>981</td><td>12.6</td></tr> <tr><td>19時～20時</td><td>105</td><td>748</td><td>853</td><td>12.3</td></tr> <tr><td>20時～21時</td><td>90</td><td>644</td><td>734</td><td>12.3</td></tr> <tr><td>21時～22時</td><td>74</td><td>564</td><td>638</td><td>11.6</td></tr> <tr><td>22時～23時</td><td>63</td><td>474</td><td>537</td><td>11.7</td></tr> <tr><td>計</td><td>2,305</td><td>13,375</td><td>15,680</td><td>14.7</td></tr> </table>				8時～9時	216	1,318	1,534	14.1	9時～10時	233	1,019	1,252	18.6	10時～11時	216	1,000	1,216	17.8	11時～12時	196	982	1,178	16.6	12時～13時	194	965	1,159	16.7	13時～14時	174	960	1,134	15.3	14時～15時	166	865	1,031	16.1	15時～16時	155	988	1,143	13.6	16時～17時	148	1,048	1,196	12.4	17時～18時	151	943	1,094	13.8	18時～19時	124	857	981	12.6	19時～20時	105	748	853	12.3	20時～21時	90	644	734	12.3	21時～22時	74	564	638	11.6	22時～23時	63	474	537	11.7	計	2,305	13,375	15,680	14.7
8時～9時	216	1,318	1,534	14.1																																																																																
9時～10時	233	1,019	1,252	18.6																																																																																
10時～11時	216	1,000	1,216	17.8																																																																																
11時～12時	196	982	1,178	16.6																																																																																
12時～13時	194	965	1,159	16.7																																																																																
13時～14時	174	960	1,134	15.3																																																																																
14時～15時	166	865	1,031	16.1																																																																																
15時～16時	155	988	1,143	13.6																																																																																
16時～17時	148	1,048	1,196	12.4																																																																																
17時～18時	151	943	1,094	13.8																																																																																
18時～19時	124	857	981	12.6																																																																																
19時～20時	105	748	853	12.3																																																																																
20時～21時	90	644	734	12.3																																																																																
21時～22時	74	564	638	11.6																																																																																
22時～23時	63	474	537	11.7																																																																																
計	2,305	13,375	15,680	14.7																																																																																

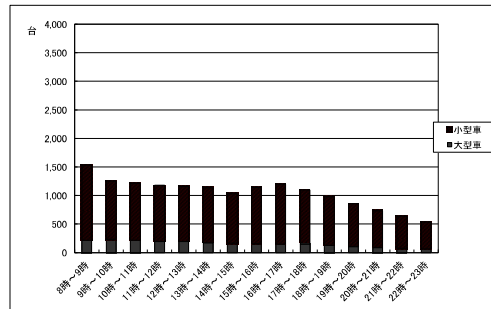

地点	No.2																																																																																																																																																																																																																																																																																																																																	
調査日	令和7年10月27日(月)																																																																																																																																																																																																																																																																																																																																	
天候	曇り																																																																																																																																																																																																																																																																																																																																	
概要	当交差点の交通量ピークは14時～15時であった。																																																																																																																																																																																																																																																																																																																																	
調査方向区分	AからDへ右折 方向1			AからCへ直進 方向2			AからBへ左折 方向3			BからAへ右折 方向4			BからDへ直進 方向5			BからCへ左折 方向6																																																																																																																																																																																																																																																																																																																		
車両区分	大型車	小型車	合計	大型車	小型車	合計	大型車	小型車	合計	大型車	小型車	合計	大型車	小型車	合計	大型車	小型車	合計																																																																																																																																																																																																																																																																																																																
時刻	<table border="1"> <tr><td>8時～9時</td><td>4</td><td>27</td><td>31</td><td>23</td><td>211</td><td>234</td><td>0</td><td>9</td><td>9</td><td>3</td><td>10</td><td>13</td><td>41</td><td>175</td><td>216</td><td>30</td><td>151</td><td>181</td></tr> <tr><td>9時～10時</td><td>3</td><td>40</td><td>43</td><td>39</td><td>258</td><td>297</td><td>1</td><td>12</td><td>13</td><td>2</td><td>22</td><td>24</td><td>43</td><td>261</td><td>304</td><td>37</td><td>130</td><td>167</td></tr> <tr><td>10時～11時</td><td>4</td><td>51</td><td>55</td><td>40</td><td>284</td><td>324</td><td>0</td><td>18</td><td>18</td><td>5</td><td>26</td><td>31</td><td>50</td><td>309</td><td>359</td><td>52</td><td>132</td><td>184</td></tr> <tr><td>11時～12時</td><td>4</td><td>58</td><td>62</td><td>28</td><td>265</td><td>293</td><td>2</td><td>14</td><td>16</td><td>2</td><td>24</td><td>26</td><td>52</td><td>352</td><td>404</td><td>42</td><td>124</td><td>166</td></tr> <tr><td>12時～13時</td><td>2</td><td>53</td><td>55</td><td>22</td><td>188</td><td>210</td><td>1</td><td>10</td><td>11</td><td>3</td><td>18</td><td>21</td><td>51</td><td>314</td><td>365</td><td>48</td><td>98</td><td>146</td></tr> <tr><td>13時～14時</td><td>7</td><td>49</td><td>56</td><td>25</td><td>237</td><td>262</td><td>1</td><td>8</td><td>9</td><td>3</td><td>24</td><td>27</td><td>58</td><td>332</td><td>390</td><td>39</td><td>109</td><td>148</td></tr> <tr><td>14時～15時</td><td>4</td><td>52</td><td>56</td><td>28</td><td>269</td><td>297</td><td>0</td><td>12</td><td>12</td><td>2</td><td>30</td><td>32</td><td>54</td><td>356</td><td>410</td><td>32</td><td>128</td><td>160</td></tr> <tr><td>15時～16時</td><td>3</td><td>38</td><td>41</td><td>36</td><td>228</td><td>264</td><td>3</td><td>10</td><td>13</td><td>1</td><td>32</td><td>33</td><td>28</td><td>270</td><td>298</td><td>31</td><td>126</td><td>157</td></tr> <tr><td>16時～17時</td><td>2</td><td>57</td><td>59</td><td>14</td><td>263</td><td>277</td><td>0</td><td>17</td><td>17</td><td>2</td><td>34</td><td>36</td><td>22</td><td>294</td><td>316</td><td>33</td><td>154</td><td>187</td></tr> <tr><td>17時～18時</td><td>2</td><td>34</td><td>36</td><td>12</td><td>256</td><td>268</td><td>0</td><td>13</td><td>13</td><td>1</td><td>19</td><td>20</td><td>14</td><td>260</td><td>274</td><td>28</td><td>132</td><td>160</td></tr> <tr><td>18時～19時</td><td>1</td><td>40</td><td>41</td><td>20</td><td>239</td><td>259</td><td>1</td><td>11</td><td>12</td><td>1</td><td>27</td><td>28</td><td>13</td><td>243</td><td>256</td><td>21</td><td>117</td><td>138</td></tr> <tr><td>19時～20時</td><td>2</td><td>37</td><td>39</td><td>22</td><td>182</td><td>204</td><td>0</td><td>9</td><td>9</td><td>0</td><td>24</td><td>24</td><td>16</td><td>219</td><td>235</td><td>22</td><td>98</td><td>120</td></tr> <tr><td>20時～21時</td><td>3</td><td>29</td><td>32</td><td>18</td><td>145</td><td>163</td><td>0</td><td>9</td><td>9</td><td>1</td><td>21</td><td>22</td><td>11</td><td>174</td><td>185</td><td>16</td><td>79</td><td>95</td></tr> <tr><td>21時～22時</td><td>2</td><td>25</td><td>27</td><td>13</td><td>102</td><td>115</td><td>1</td><td>6</td><td>7</td><td>1</td><td>19</td><td>20</td><td>14</td><td>159</td><td>173</td><td>13</td><td>55</td><td>68</td></tr> <tr><td>22時～23時</td><td>2</td><td>13</td><td>15</td><td>11</td><td>74</td><td>85</td><td>0</td><td>5</td><td>5</td><td>0</td><td>14</td><td>14</td><td>9</td><td>132</td><td>141</td><td>11</td><td>38</td><td>49</td></tr> <tr><td>計</td><td>45</td><td>603</td><td>648</td><td>351</td><td>3,201</td><td>3,552</td><td>10</td><td>163</td><td>173</td><td>27</td><td>344</td><td>371</td><td>476</td><td>3,850</td><td>4,326</td><td>455</td><td>1,671</td><td>2,126</td></tr> </table>																		8時～9時	4	27	31	23	211	234	0	9	9	3	10	13	41	175	216	30	151	181	9時～10時	3	40	43	39	258	297	1	12	13	2	22	24	43	261	304	37	130	167	10時～11時	4	51	55	40	284	324	0	18	18	5	26	31	50	309	359	52	132	184	11時～12時	4	58	62	28	265	293	2	14	16	2	24	26	52	352	404	42	124	166	12時～13時	2	53	55	22	188	210	1	10	11	3	18	21	51	314	365	48	98	146	13時～14時	7	49	56	25	237	262	1	8	9	3	24	27	58	332	390	39	109	148	14時～15時	4	52	56	28	269	297	0	12	12	2	30	32	54	356	410	32	128	160	15時～16時	3	38	41	36	228	264	3	10	13	1	32	33	28	270	298	31	126	157	16時～17時	2	57	59	14	263	277	0	17	17	2	34	36	22	294	316	33	154	187	17時～18時	2	34	36	12	256	268	0	13	13	1	19	20	14	260	274	28	132	160	18時～19時	1	40	41	20	239	259	1	11	12	1	27	28	13	243	256	21	117	138	19時～20時	2	37	39	22	182	204	0	9	9	0	24	24	16	219	235	22	98	120	20時～21時	3	29	32	18	145	163	0	9	9	1	21	22	11	174	185	16	79	95	21時～22時	2	25	27	13	102	115	1	6	7	1	19	20	14	159	173	13	55	68	22時～23時	2	13	15	11	74	85	0	5	5	0	14	14	9	132	141	11	38	49	計	45	603	648	351	3,201	3,552	10	163	173	27	344	371	476	3,850	4,326	455	1,671	2,126
8時～9時	4	27	31	23	211	234	0	9	9	3	10	13	41	175	216	30	151	181																																																																																																																																																																																																																																																																																																																
9時～10時	3	40	43	39	258	297	1	12	13	2	22	24	43	261	304	37	130	167																																																																																																																																																																																																																																																																																																																
10時～11時	4	51	55	40	284	324	0	18	18	5	26	31	50	309	359	52	132	184																																																																																																																																																																																																																																																																																																																
11時～12時	4	58	62	28	265	293	2	14	16	2	24	26	52	352	404	42	124	166																																																																																																																																																																																																																																																																																																																
12時～13時	2	53	55	22	188	210	1	10	11	3	18	21	51	314	365	48	98	146																																																																																																																																																																																																																																																																																																																
13時～14時	7	49	56	25	237	262	1	8	9	3	24	27	58	332	390	39	109	148																																																																																																																																																																																																																																																																																																																
14時～15時	4	52	56	28	269	297	0	12	12	2	30	32	54	356	410	32	128	160																																																																																																																																																																																																																																																																																																																
15時～16時	3	38	41	36	228	264	3	10	13	1	32	33	28	270	298	31	126	157																																																																																																																																																																																																																																																																																																																
16時～17時	2	57	59	14	263	277	0	17	17	2	34	36	22	294	316	33	154	187																																																																																																																																																																																																																																																																																																																
17時～18時	2	34	36	12	256	268	0	13	13	1	19	20	14	260	274	28	132	160																																																																																																																																																																																																																																																																																																																
18時～19時	1	40	41	20	239	259	1	11	12	1	27	28	13	243	256	21	117	138																																																																																																																																																																																																																																																																																																																
19時～20時	2	37	39	22	182	204	0	9	9	0	24	24	16	219	235	22	98	120																																																																																																																																																																																																																																																																																																																
20時～21時	3	29	32	18	145	163	0	9	9	1	21	22	11	174	185	16	79	95																																																																																																																																																																																																																																																																																																																
21時～22時	2	25	27	13	102	115	1	6	7	1	19	20	14	159	173	13	55	68																																																																																																																																																																																																																																																																																																																
22時～23時	2	13	15	11	74	85	0	5	5	0	14	14	9	132	141	11	38	49																																																																																																																																																																																																																																																																																																																
計	45	603	648	351	3,201	3,552	10	163	173	27	344	371	476	3,850	4,326	455	1,671	2,126																																																																																																																																																																																																																																																																																																																

調査方向区分	CからBへ右折 方向7			CからAへ直進 方向8			CからDへ左折 方向9			DからCへ右折 方向10			DからBへ直進 方向11			DからAへ左折 方向12																																																																																																																																																																																																																																																																																																																		
車両区分	大型車	小型車	合計	大型車	小型車	合計	大型車	小型車	合計	大型車	小型車	合計	大型車	小型車	合計	大型車	小型車	合計																																																																																																																																																																																																																																																																																																																
時刻	<table border="1"> <tr><td>8時～9時</td><td>32</td><td>71</td><td>103</td><td>20</td><td>166</td><td>186</td><td>8</td><td>65</td><td>73</td><td>16</td><td>69</td><td>85</td><td>36</td><td>140</td><td>176</td><td>2</td><td>23</td><td>25</td></tr> <tr><td>9時～10時</td><td>27</td><td>94</td><td>121</td><td>31</td><td>189</td><td>220</td><td>9</td><td>73</td><td>82</td><td>19</td><td>77</td><td>96</td><td>49</td><td>227</td><td>276</td><td>4</td><td>26</td><td>30</td></tr> <tr><td>10時～11時</td><td>44</td><td>90</td><td>134</td><td>26</td><td>202</td><td>228</td><td>7</td><td>90</td><td>97</td><td>10</td><td>92</td><td>102</td><td>30</td><td>245</td><td>275</td><td>4</td><td>49</td><td>53</td></tr> <tr><td>11時～12時</td><td>32</td><td>81</td><td>113</td><td>19</td><td>176</td><td>195</td><td>9</td><td>133</td><td>142</td><td>6</td><td>117</td><td>123</td><td>45</td><td>341</td><td>386</td><td>5</td><td>52</td><td>57</td></tr> <tr><td>12時～13時</td><td>19</td><td>94</td><td>113</td><td>31</td><td>174</td><td>205</td><td>3</td><td>104</td><td>107</td><td>8</td><td>118</td><td>126</td><td>31</td><td>316</td><td>347</td><td>3</td><td>57</td><td>60</td></tr> <tr><td>13時～14時</td><td>24</td><td>105</td><td>129</td><td>27</td><td>193</td><td>220</td><td>4</td><td>94</td><td>98</td><td>7</td><td>109</td><td>116</td><td>41</td><td>324</td><td>365</td><td>3</td><td>72</td><td>75</td></tr> <tr><td>14時～15時</td><td>42</td><td>114</td><td>156</td><td>26</td><td>238</td><td>264</td><td>2</td><td>88</td><td>90</td><td>6</td><td>112</td><td>118</td><td>50</td><td>346</td><td>396</td><td>4</td><td>55</td><td>59</td></tr> <tr><td>15時～16時</td><td>24</td><td>87</td><td>111</td><td>26</td><td>188</td><td>214</td><td>5</td><td>76</td><td>81</td><td>4</td><td>113</td><td>117</td><td>38</td><td>299</td><td>337</td><td>5</td><td>56</td><td>61</td></tr> <tr><td>16時～17時</td><td>19</td><td>134</td><td>153</td><td>14</td><td>221</td><td>235</td><td>2</td><td>101</td><td>103</td><td>3</td><td>119</td><td>122</td><td>26</td><td>354</td><td>380</td><td>3</td><td>60</td><td>63</td></tr> <tr><td>17時～18時</td><td>17</td><td>115</td><td>132</td><td>15</td><td>224</td><td>239</td><td>2</td><td>78</td><td>80</td><td>6</td><td>94</td><td>100</td><td>18</td><td>278</td><td>296</td><td>2</td><td>47</td><td>49</td></tr> <tr><td>18時～19時</td><td>15</td><td>109</td><td>124</td><td>19</td><td>192</td><td>211</td><td>1</td><td>77</td><td>78</td><td>4</td><td>78</td><td>82</td><td>15</td><td>251</td><td>266</td><td>1</td><td>44</td><td>45</td></tr> <tr><td>19時～20時</td><td>16</td><td>83</td><td>99</td><td>13</td><td>166</td><td>179</td><td>4</td><td>65</td><td>69</td><td>5</td><td>72</td><td>77</td><td>11</td><td>217</td><td>228</td><td>2</td><td>33</td><td>35</td></tr> <tr><td>20時～21時</td><td>14</td><td>61</td><td>75</td><td>10</td><td>139</td><td>149</td><td>2</td><td>61</td><td>63</td><td>5</td><td>68</td><td>73</td><td>9</td><td>173</td><td>182</td><td>0</td><td>35</td><td>35</td></tr> <tr><td>21時～22時</td><td>11</td><td>40</td><td>51</td><td>7</td><td>89</td><td>96</td><td>2</td><td>48</td><td>50</td><td>3</td><td>57</td><td>60</td><td>7</td><td>149</td><td>156</td><td>1</td><td>29</td><td>30</td></tr> <tr><td>22時～23時</td><td>7</td><td>33</td><td>40</td><td>6</td><td>67</td><td>73</td><td>1</td><td>29</td><td>30</td><td>2</td><td>44</td><td>46</td><td>5</td><td>123</td><td>128</td><td>0</td><td>23</td><td>23</td></tr> <tr><td>計</td><td>343</td><td>1,311</td><td>1,654</td><td>290</td><td>2,624</td><td>2,914</td><td>61</td><td>1,182</td><td>1,243</td><td>104</td><td>1,339</td><td>1,443</td><td>411</td><td>3,783</td><td>4,194</td><td>39</td><td>661</td><td>700</td></tr> </table>																		8時～9時	32	71	103	20	166	186	8	65	73	16	69	85	36	140	176	2	23	25	9時～10時	27	94	121	31	189	220	9	73	82	19	77	96	49	227	276	4	26	30	10時～11時	44	90	134	26	202	228	7	90	97	10	92	102	30	245	275	4	49	53	11時～12時	32	81	113	19	176	195	9	133	142	6	117	123	45	341	386	5	52	57	12時～13時	19	94	113	31	174	205	3	104	107	8	118	126	31	316	347	3	57	60	13時～14時	24	105	129	27	193	220	4	94	98	7	109	116	41	324	365	3	72	75	14時～15時	42	114	156	26	238	264	2	88	90	6	112	118	50	346	396	4	55	59	15時～16時	24	87	111	26	188	214	5	76	81	4	113	117	38	299	337	5	56	61	16時～17時	19	134	153	14	221	235	2	101	103	3	119	122	26	354	380	3	60	63	17時～18時	17	115	132	15	224	239	2	78	80	6	94	100	18	278	296	2	47	49	18時～19時	15	109	124	19	192	211	1	77	78	4	78	82	15	251	266	1	44	45	19時～20時	16	83	99	13	166	179	4	65	69	5	72	77	11	217	228	2	33	35	20時～21時	14	61	75	10	139	149	2	61	63	5	68	73	9	173	182	0	35	35	21時～22時	11	40	51	7	89	96	2	48	50	3	57	60	7	149	156	1	29	30	22時～23時	7	33	40	6	67	73	1	29	30	2	44	46	5	123	128	0	23	23	計	343	1,311	1,654	290	2,624	2,914	61	1,182	1,243	104	1,339	1,443	411	3,783	4,194	39	661	700
8時～9時	32	71	103	20	166	186	8	65	73	16	69	85	36	140	176	2	23	25																																																																																																																																																																																																																																																																																																																
9時～10時	27	94	121	31	189	220	9	73	82	19	77	96	49	227	276	4	26	30																																																																																																																																																																																																																																																																																																																
10時～11時	44	90	134	26	202	228	7	90	97	10	92	102	30	245	275	4	49	53																																																																																																																																																																																																																																																																																																																
11時～12時	32	81	113	19	176	195	9	133	142	6	117	123	45	341	386	5	52	57																																																																																																																																																																																																																																																																																																																
12時～13時	19	94	113	31	174	205	3	104	107	8	118	126	31	316	347	3	57	60																																																																																																																																																																																																																																																																																																																
13時～14時	24	105	129	27	193	220	4	94	98	7	109	116	41	324	365	3	72	75																																																																																																																																																																																																																																																																																																																
14時～15時	42	114	156	26	238	264	2	88	90	6	112	118	50	346	396	4	55	59																																																																																																																																																																																																																																																																																																																
15時～16時	24	87	111	26	188	214	5	76	81	4	113	117	38	299	337	5	56	61																																																																																																																																																																																																																																																																																																																
16時～17時	19	134	153	14	221	235	2	101	103	3	119	122	26	354	380	3	60	63																																																																																																																																																																																																																																																																																																																
17時～18時	17	115	132	15	224	239	2	78	80	6	94	100	18	278	296	2	47	49																																																																																																																																																																																																																																																																																																																
18時～19時	15	109	124	19	192	211	1	77	78	4	78	82	15	251	266	1	44	45																																																																																																																																																																																																																																																																																																																
19時～20時	16	83	99	13	166	179	4	65	69	5	72	77	11	217	228	2	33	35																																																																																																																																																																																																																																																																																																																
20時～21時	14	61	75	10	139	149	2	61	63	5	68	73	9	173	182	0	35	35																																																																																																																																																																																																																																																																																																																
21時～22時	11	40	51	7	89	96	2	48	50	3	57	60	7	149	156	1	29	30																																																																																																																																																																																																																																																																																																																
22時～23時	7	33	40	6	67	73	1	29	30	2	44	46	5	123	128	0	23	23																																																																																																																																																																																																																																																																																																																
計	343	1,311	1,654	290	2,624	2,914	61	1,182	1,243	104	1,339	1,443	411	3,783	4,194	39	661	700																																																																																																																																																																																																																																																																																																																

調査方向区分	全方向																																																																																			
車両区分	大型車	小型車	合計	大型車混入率(%)																																																																																
時刻	<table border="1"> <tr><td>8時～9時</td><td>215</td><td>1,117</td><td>1,332</td><td>16.1</td></tr> <tr><td>9時～10時</td><td>264</td><td>1,409</td><td>1,673</td><td>15.8</td></tr> <tr><td>10時～11時</td><td>272</td><td>1,588</td><td>1,860</td><td>14.6</td></tr> <tr><td>11時～12時</td><td>246</td><td>1,737</td><td>1,983</td><td>12.4</td></tr> <tr><td>12時～13時</td><td>222</td><td>1,544</td><td>1,766</td><td>12.6</td></tr> <tr><td>13時～14時</td><td>239</td><td>1,656</td><td>1,895</td><td>12.6</td></tr> <tr><td>14時～15時</td><td>250</td><td>1,800</td><td>2,050</td><td>12.2</td></tr> <tr><td>15時～16時</td><td>204</td><td>1,523</td><td>1,727</td><td>11.8</td></tr> <tr><td>16時～17時</td><td>140</td><td>1,808</td><td>1,948</td><td>7.2</td></tr> <tr><td>17時～18時</td><td>117</td><td>1,550</td><td>1,667</td><td>7.0</td></tr> <tr><td>18時～19時</td><td>112</td><td>1,428</td><td>1,540</td><td>7.3</td></tr> <tr><td>19時～20時</td><td>113</td><td>1,205</td><td>1,318</td><td>8.6</td></tr> <tr><td>20時～21時</td><td>89</td><td>994</td><td>1,083</td><td>8.2</td></tr> <tr><td>21時～22時</td><td>75</td><td>778</td><td>853</td><td>8.8</td></tr> <tr><td>22時～23時</td><td>54</td><td>595</td><td>649</td><td>8.3</td></tr> <tr><td>計</td><td>2,612</td><td>20,732</td><td>23,344</td><td>11.2</td></tr> </table>				8時～9時	215	1,117	1,332	16.1	9時～10時	264	1,409	1,673	15.8	10時～11時	272	1,588	1,860	14.6	11時～12時	246	1,737	1,983	12.4	12時～13時	222	1,544	1,766	12.6	13時～14時	239	1,656	1,895	12.6	14時～15時	250	1,800	2,050	12.2	15時～16時	204	1,523	1,727	11.8	16時～17時	140	1,808	1,948	7.2	17時～18時	117	1,550	1,667	7.0	18時～19時	112	1,428	1,540	7.3	19時～20時	113	1,205	1,318	8.6	20時～21時	89	994	1,083	8.2	21時～22時	75	778	853	8.8	22時～23時	54	595	649	8.3	計	2,612	20,732	23,344	11.2
8時～9時	215	1,117	1,332	16.1																																																																																
9時～10時	264	1,409	1,673	15.8																																																																																
10時～11時	272	1,588	1,860	14.6																																																																																
11時～12時	246	1,737	1,983	12.4																																																																																
12時～13時	222	1,544	1,766	12.6																																																																																
13時～14時	239	1,656	1,895	12.6																																																																																
14時～15時	250	1,800	2,050	12.2																																																																																
15時～16時	204	1,523	1,727	11.8																																																																																
16時～17時	140	1,808	1,948	7.2																																																																																
17時～18時	117	1,550	1,667	7.0																																																																																
18時～19時	112	1,428	1,540	7.3																																																																																
19時～20時	113	1,205	1,318	8.6																																																																																
20時～21時	89	994	1,083	8.2																																																																																
21時～22時	75	778	853	8.8																																																																																
22時～23時	54	595	649	8.3																																																																																
計	2,612	20,732	23,344	11.2																																																																																

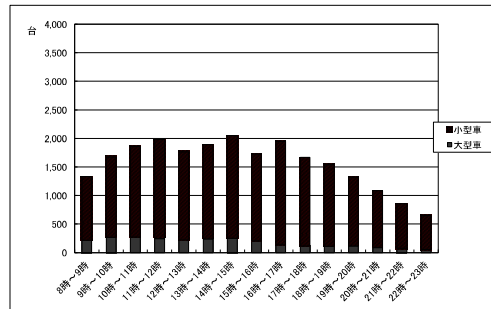

地点	No.3																																																																																																																																																																																																																																																																																																																																	
調査日	令和7年10月27日(月)																																																																																																																																																																																																																																																																																																																																	
天候	曇り																																																																																																																																																																																																																																																																																																																																	
概要	当交差点の交通量ピークは8時～9時であった。																																																																																																																																																																																																																																																																																																																																	
調査方向区分	AからDへ右折 方向1			AからCへ直進 方向2			AからBへ左折 方向3			BからAへ右折 方向4			BからDへ直進 方向5			BからCへ左折 方向6																																																																																																																																																																																																																																																																																																																		
車両区分	大型車	小型車	合計	大型車	小型車	合計	大型車	小型車	合計	大型車	小型車	合計	大型車	小型車	合計	大型車	小型車	合計																																																																																																																																																																																																																																																																																																																
時刻	<table border="1"> <tr><td>8時～9時</td><td>9</td><td>75</td><td>84</td><td>66</td><td>538</td><td>604</td><td>3</td><td>29</td><td>32</td><td>5</td><td>35</td><td>40</td><td>18</td><td>239</td><td>257</td><td>26</td><td>88</td><td>114</td></tr> <tr><td>9時～10時</td><td>13</td><td>37</td><td>50</td><td>70</td><td>387</td><td>457</td><td>5</td><td>46</td><td>51</td><td>2</td><td>30</td><td>32</td><td>17</td><td>231</td><td>248</td><td>14</td><td>72</td><td>86</td></tr> <tr><td>10時～11時</td><td>14</td><td>30</td><td>44</td><td>86</td><td>362</td><td>448</td><td>3</td><td>40</td><td>43</td><td>4</td><td>38</td><td>42</td><td>23</td><td>214</td><td>237</td><td>15</td><td>104</td><td>119</td></tr> <tr><td>11時～12時</td><td>7</td><td>52</td><td>59</td><td>80</td><td>332</td><td>412</td><td>6</td><td>56</td><td>62</td><td>5</td><td>41</td><td>46</td><td>8</td><td>289</td><td>297</td><td>16</td><td>102</td><td>118</td></tr> <tr><td>12時～13時</td><td>8</td><td>80</td><td>88</td><td>62</td><td>296</td><td>358</td><td>4</td><td>50</td><td>54</td><td>2</td><td>43</td><td>45</td><td>19</td><td>268</td><td>287</td><td>18</td><td>118</td><td>136</td></tr> <tr><td>13時～14時</td><td>5</td><td>66</td><td>71</td><td>69</td><td>277</td><td>346</td><td>5</td><td>48</td><td>53</td><td>4</td><td>39</td><td>43</td><td>15</td><td>254</td><td>269</td><td>21</td><td>93</td><td>114</td></tr> <tr><td>14時～15時</td><td>8</td><td>41</td><td>49</td><td>71</td><td>261</td><td>332</td><td>6</td><td>42</td><td>48</td><td>6</td><td>28</td><td>34</td><td>22</td><td>262</td><td>284</td><td>20</td><td>84</td><td>104</td></tr> <tr><td>15時～16時</td><td>7</td><td>32</td><td>39</td><td>57</td><td>285</td><td>342</td><td>3</td><td>34</td><td>37</td><td>12</td><td>32</td><td>44</td><td>13</td><td>231</td><td>244</td><td>9</td><td>73</td><td>82</td></tr> <tr><td>16時～17時</td><td>8</td><td>44</td><td>52</td><td>54</td><td>366</td><td>420</td><td>1</td><td>46</td><td>47</td><td>7</td><td>36</td><td>43</td><td>8</td><td>250</td><td>258</td><td>10</td><td>104</td><td>114</td></tr> <tr><td>17時～18時</td><td>3</td><td>46</td><td>49</td><td>39</td><td>361</td><td>400</td><td>4</td><td>39</td><td>43</td><td>5</td><td>49</td><td>54</td><td>16</td><td>204</td><td>220</td><td>16</td><td>126</td><td>142</td></tr> <tr><td>18時～19時</td><td>2</td><td>43</td><td>45</td><td>30</td><td>344</td><td>374</td><td>2</td><td>33</td><td>35</td><td>4</td><td>44</td><td>48</td><td>14</td><td>175</td><td>189</td><td>13</td><td>111</td><td>124</td></tr> <tr><td>19時～20時</td><td>3</td><td>45</td><td>48</td><td>21</td><td>298</td><td>319</td><td>2</td><td>27</td><td>29</td><td>5</td><td>41</td><td>46</td><td>11</td><td>166</td><td>177</td><td>10</td><td>80</td><td>90</td></tr> <tr><td>20時～21時</td><td>2</td><td>38</td><td>40</td><td>19</td><td>241</td><td>260</td><td>1</td><td>21</td><td>22</td><td>3</td><td>39</td><td>42</td><td>8</td><td>140</td><td>148</td><td>8</td><td>82</td><td>90</td></tr> <tr><td>21時～22時</td><td>3</td><td>32</td><td>35</td><td>16</td><td>198</td><td>214</td><td>0</td><td>20</td><td>20</td><td>3</td><td>35</td><td>38</td><td>5</td><td>147</td><td>152</td><td>7</td><td>69</td><td>76</td></tr> <tr><td>22時～23時</td><td>2</td><td>30</td><td>32</td><td>11</td><td>174</td><td>185</td><td>1</td><td>17</td><td>18</td><td>2</td><td>23</td><td>25</td><td>4</td><td>129</td><td>133</td><td>5</td><td>44</td><td>49</td></tr> <tr><td>計</td><td>94</td><td>691</td><td>785</td><td>751</td><td>4,720</td><td>5,471</td><td>46</td><td>548</td><td>594</td><td>69</td><td>553</td><td>622</td><td>201</td><td>3,199</td><td>3,400</td><td>208</td><td>1,350</td><td>1,558</td></tr> </table>																		8時～9時	9	75	84	66	538	604	3	29	32	5	35	40	18	239	257	26	88	114	9時～10時	13	37	50	70	387	457	5	46	51	2	30	32	17	231	248	14	72	86	10時～11時	14	30	44	86	362	448	3	40	43	4	38	42	23	214	237	15	104	119	11時～12時	7	52	59	80	332	412	6	56	62	5	41	46	8	289	297	16	102	118	12時～13時	8	80	88	62	296	358	4	50	54	2	43	45	19	268	287	18	118	136	13時～14時	5	66	71	69	277	346	5	48	53	4	39	43	15	254	269	21	93	114	14時～15時	8	41	49	71	261	332	6	42	48	6	28	34	22	262	284	20	84	104	15時～16時	7	32	39	57	285	342	3	34	37	12	32	44	13	231	244	9	73	82	16時～17時	8	44	52	54	366	420	1	46	47	7	36	43	8	250	258	10	104	114	17時～18時	3	46	49	39	361	400	4	39	43	5	49	54	16	204	220	16	126	142	18時～19時	2	43	45	30	344	374	2	33	35	4	44	48	14	175	189	13	111	124	19時～20時	3	45	48	21	298	319	2	27	29	5	41	46	11	166	177	10	80	90	20時～21時	2	38	40	19	241	260	1	21	22	3	39	42	8	140	148	8	82	90	21時～22時	3	32	35	16	198	214	0	20	20	3	35	38	5	147	152	7	69	76	22時～23時	2	30	32	11	174	185	1	17	18	2	23	25	4	129	133	5	44	49	計	94	691	785	751	4,720	5,471	46	548	594	69	553	622	201	3,199	3,400	208	1,350	1,558
8時～9時	9	75	84	66	538	604	3	29	32	5	35	40	18	239	257	26	88	114																																																																																																																																																																																																																																																																																																																
9時～10時	13	37	50	70	387	457	5	46	51	2	30	32	17	231	248	14	72	86																																																																																																																																																																																																																																																																																																																
10時～11時	14	30	44	86	362	448	3	40	43	4	38	42	23	214	237	15	104	119																																																																																																																																																																																																																																																																																																																
11時～12時	7	52	59	80	332	412	6	56	62	5	41	46	8	289	297	16	102	118																																																																																																																																																																																																																																																																																																																
12時～13時	8	80	88	62	296	358	4	50	54	2	43	45	19	268	287	18	118	136																																																																																																																																																																																																																																																																																																																
13時～14時	5	66	71	69	277	346	5	48	53	4	39	43	15	254	269	21	93	114																																																																																																																																																																																																																																																																																																																
14時～15時	8	41	49	71	261	332	6	42	48	6	28	34	22	262	284	20	84	104																																																																																																																																																																																																																																																																																																																
15時～16時	7	32	39	57	285	342	3	34	37	12	32	44	13	231	244	9	73	82																																																																																																																																																																																																																																																																																																																
16時～17時	8	44	52	54	366	420	1	46	47	7	36	43	8	250	258	10	104	114																																																																																																																																																																																																																																																																																																																
17時～18時	3	46	49	39	361	400	4	39	43	5	49	54	16	204	220	16	126	142																																																																																																																																																																																																																																																																																																																
18時～19時	2	43	45	30	344	374	2	33	35	4	44	48	14	175	189	13	111	124																																																																																																																																																																																																																																																																																																																
19時～20時	3	45	48	21	298	319	2	27	29	5	41	46	11	166	177	10	80	90																																																																																																																																																																																																																																																																																																																
20時～21時	2	38	40	19	241	260	1	21	22	3	39	42	8	140	148	8	82	90																																																																																																																																																																																																																																																																																																																
21時～22時	3	32	35	16	198	214	0	20	20	3	35	38	5	147	152	7	69	76																																																																																																																																																																																																																																																																																																																
22時～23時	2	30	32	11	174	185	1	17	18	2	23	25	4	129	133	5	44	49																																																																																																																																																																																																																																																																																																																
計	94	691	785	751	4,720	5,471	46	548	594	69	553	622	201	3,199	3,400	208	1,350	1,558																																																																																																																																																																																																																																																																																																																

調査方向区分	CからBへ右折 方向7			CからAへ直進 方向8			CからDへ左折 方向9			DからCへ右折 方向10			DからBへ直進 方向11			DからAへ左折 方向12																																																																																																																																																																																																																																																																																																																		
車両区分	大型車	小型車	合計	大型車	小型車	合計	大型車	小型車	合計	大型車	小型車	合計	大型車	小型車	合計	大型車	小型車	合計																																																																																																																																																																																																																																																																																																																
時刻	<table border="1"> <tr><td>8時～9時</td><td>39</td><td>127</td><td>166</td><td>104</td><td>387</td><td>491</td><td>16</td><td>63</td><td>79</td><td>11</td><td>95</td><td>106</td><td>17</td><td>270</td><td>287</td><td>2</td><td>18</td><td>20</td></tr> <tr><td>9時～10時</td><td>21</td><td>115</td><td>136</td><td>125</td><td>243</td><td>368</td><td>14</td><td>40</td><td>54</td><td>9</td><td>58</td><td>67</td><td>16</td><td>272</td><td>288</td><td>7</td><td>17</td><td>24</td></tr> <tr><td>10時～11時</td><td>30</td><td>108</td><td>138</td><td>122</td><td>258</td><td>380</td><td>18</td><td>34</td><td>52</td><td>6</td><td>69</td><td>75</td><td>16</td><td>336</td><td>352</td><td>4</td><td>22</td><td>26</td></tr> <tr><td>11時～12時</td><td>23</td><td>179</td><td>202</td><td>111</td><td>323</td><td>434</td><td>12</td><td>65</td><td>77</td><td>7</td><td>57</td><td>64</td><td>19</td><td>358</td><td>377</td><td>10</td><td>32</td><td>42</td></tr> <tr><td>12時～13時</td><td>19</td><td>168</td><td>187</td><td>104</td><td>280</td><td>384</td><td>8</td><td>44</td><td>52</td><td>10</td><td>84</td><td>94</td><td>10</td><td>326</td><td>336</td><td>6</td><td>44</td><td>50</td></tr> <tr><td>13時～14時</td><td>17</td><td>149</td><td>166</td><td>99</td><td>299</td><td>398</td><td>10</td><td>53</td><td>63</td><td>9</td><td>77</td><td>86</td><td>15</td><td>277</td><td>292</td><td>7</td><td>39</td><td>46</td></tr> <tr><td>14時～15時</td><td>21</td><td>160</td><td>181</td><td>92</td><td>326</td><td>418</td><td>14</td><td>48</td><td>62</td><td>10</td><td>71</td><td>81</td><td>20</td><td>224</td><td>244</td><td>5</td><td>14</td><td>19</td></tr> <tr><td>15時～16時</td><td>18</td><td>164</td><td>182</td><td>91</td><td>305</td><td>396</td><td>10</td><td>37</td><td>47</td><td>13</td><td>60</td><td>73</td><td>14</td><td>261</td><td>275</td><td>3</td><td>18</td><td>21</td></tr> <tr><td>16時～17時</td><td>8</td><td>190</td><td>198</td><td>74</td><td>461</td><td>535</td><td>6</td><td>56</td><td>62</td><td>8</td><td>57</td><td>65</td><td>17</td><td>315</td><td>332</td><td>3</td><td>20</td><td>23</td></tr> <tr><td>17時～18時</td><td>9</td><td>186</td><td>195</td><td>65</td><td>426</td><td>491</td><td>5</td><td>62</td><td>67</td><td>6</td><td>60</td><td>66</td><td>6</td><td>384</td><td>390</td><td>2</td><td>26</td><td>28</td></tr> <tr><td>18時～19時</td><td>7</td><td>162</td><td>169</td><td>49</td><td>392</td><td>441</td><td>4</td><td>59</td><td>63</td><td>5</td><td>53</td><td>58</td><td>6</td><td>360</td><td>366</td><td>3</td><td>24</td><td>27</td></tr> <tr><td>19時～20時</td><td>9</td><td>155</td><td>164</td><td>43</td><td>366</td><td>409</td><td>5</td><td>47</td><td>52</td><td>6</td><td>48</td><td>54</td><td>7</td><td>285</td><td>292</td><td>2</td><td>22</td><td>24</td></tr> <tr><td>20時～21時</td><td>7</td><td>142</td><td>149</td><td>28</td><td>329</td><td>357</td><td>3</td><td>44</td><td>47</td><td>5</td><td>44</td><td>49</td><td>5</td><td>255</td><td>260</td><td>1</td><td>19</td><td>20</td></tr> <tr><td>21時～22時</td><td>6</td><td>130</td><td>136</td><td>22</td><td>273</td><td>295</td><td>4</td><td>33</td><td>37</td><td>4</td><td>39</td><td>43</td><td>4</td><td>239</td><td>243</td><td>1</td><td>14</td><td>15</td></tr> <tr><td>22時～23時</td><td>5</td><td>103</td><td>108</td><td>18</td><td>232</td><td>250</td><td>3</td><td>28</td><td>31</td><td>3</td><td>31</td><td>34</td><td>3</td><td>201</td><td>204</td><td>2</td><td>9</td><td>11</td></tr> <tr><td>計</td><td>239</td><td>2,238</td><td>2,477</td><td>1,147</td><td>4,900</td><td>6,047</td><td>132</td><td>713</td><td>845</td><td>112</td><td>903</td><td>1,015</td><td>175</td><td>4,363</td><td>4,538</td><td>58</td><td>338</td><td>396</td></tr> </table>																		8時～9時	39	127	166	104	387	491	16	63	79	11	95	106	17	270	287	2	18	20	9時～10時	21	115	136	125	243	368	14	40	54	9	58	67	16	272	288	7	17	24	10時～11時	30	108	138	122	258	380	18	34	52	6	69	75	16	336	352	4	22	26	11時～12時	23	179	202	111	323	434	12	65	77	7	57	64	19	358	377	10	32	42	12時～13時	19	168	187	104	280	384	8	44	52	10	84	94	10	326	336	6	44	50	13時～14時	17	149	166	99	299	398	10	53	63	9	77	86	15	277	292	7	39	46	14時～15時	21	160	181	92	326	418	14	48	62	10	71	81	20	224	244	5	14	19	15時～16時	18	164	182	91	305	396	10	37	47	13	60	73	14	261	275	3	18	21	16時～17時	8	190	198	74	461	535	6	56	62	8	57	65	17	315	332	3	20	23	17時～18時	9	186	195	65	426	491	5	62	67	6	60	66	6	384	390	2	26	28	18時～19時	7	162	169	49	392	441	4	59	63	5	53	58	6	360	366	3	24	27	19時～20時	9	155	164	43	366	409	5	47	52	6	48	54	7	285	292	2	22	24	20時～21時	7	142	149	28	329	357	3	44	47	5	44	49	5	255	260	1	19	20	21時～22時	6	130	136	22	273	295	4	33	37	4	39	43	4	239	243	1	14	15	22時～23時	5	103	108	18	232	250	3	28	31	3	31	34	3	201	204	2	9	11	計	239	2,238	2,477	1,147	4,900	6,047	132	713	845	112	903	1,015	175	4,363	4,538	58	338	396
8時～9時	39	127	166	104	387	491	16	63	79	11	95	106	17	270	287	2	18	20																																																																																																																																																																																																																																																																																																																
9時～10時	21	115	136	125	243	368	14	40	54	9	58	67	16	272	288	7	17	24																																																																																																																																																																																																																																																																																																																
10時～11時	30	108	138	122	258	380	18	34	52	6	69	75	16	336	352	4	22	26																																																																																																																																																																																																																																																																																																																
11時～12時	23	179	202	111	323	434	12	65	77	7	57	64	19	358	377	10	32	42																																																																																																																																																																																																																																																																																																																
12時～13時	19	168	187	104	280	384	8	44	52	10	84	94	10	326	336	6	44	50																																																																																																																																																																																																																																																																																																																
13時～14時	17	149	166	99	299	398	10	53	63	9	77	86	15	277	292	7	39	46																																																																																																																																																																																																																																																																																																																
14時～15時	21	160	181	92	326	418	14	48	62	10	71	81	20	224	244	5	14	19																																																																																																																																																																																																																																																																																																																
15時～16時	18	164	182	91	305	396	10	37	47	13	60	73	14	261	275	3	18	21																																																																																																																																																																																																																																																																																																																
16時～17時	8	190	198	74	461	535	6	56	62	8	57	65	17	315	332	3	20	23																																																																																																																																																																																																																																																																																																																
17時～18時	9	186	195	65	426	491	5	62	67	6	60	66	6	384	390	2	26	28																																																																																																																																																																																																																																																																																																																
18時～19時	7	162	169	49	392	441	4	59	63	5	53	58	6	360	366	3	24	27																																																																																																																																																																																																																																																																																																																
19時～20時	9	155	164	43	366	409	5	47	52	6	48	54	7	285	292	2	22	24																																																																																																																																																																																																																																																																																																																
20時～21時	7	142	149	28	329	357	3	44	47	5	44	49	5	255	260	1	19	20																																																																																																																																																																																																																																																																																																																
21時～22時	6	130	136	22	273	295	4	33	37	4	39	43	4	239	243	1	14	15																																																																																																																																																																																																																																																																																																																
22時～23時	5	103	108	18	232	250	3	28	31	3	31	34	3	201	204	2	9	11																																																																																																																																																																																																																																																																																																																
計	239	2,238	2,477	1,147	4,900	6,047	132	713	845	112	903	1,015	175	4,363	4,538	58	338	396																																																																																																																																																																																																																																																																																																																

調査方向区分	全方向																																																																																			
車両区分	大型車	小型車	合計	大型車混入率(%)																																																																																
時刻	<table border="1"> <tr><td>8時～9時</td><td>316</td><td>1,964</td><td>2,280</td><td>13.9</td></tr> <tr><td>9時～10時</td><td>313</td><td>1,548</td><td>1,861</td><td>16.8</td></tr> <tr><td>10時～11時</td><td>341</td><td>1,615</td><td>1,956</td><td>17.4</td></tr> <tr><td>11時～12時</td><td>304</td><td>1,886</td><td>2,190</td><td>13.9</td></tr> <tr><td>12時～13時</td><td>270</td><td>1,801</td><td>2,071</td><td>13.0</td></tr> <tr><td>13時～14時</td><td>276</td><td>1,671</td><td>1,947</td><td>14.2</td></tr> <tr><td>14時～15時</td><td>295</td><td>1,561</td><td>1,856</td><td>15.9</td></tr> <tr><td>15時～16時</td><td>250</td><td>1,532</td><td>1,782</td><td>14.0</td></tr> <tr><td>16時～17時</td><td>204</td><td>1,945</td><td>2,149</td><td>9.5</td></tr> <tr><td>17時～18時</td><td>176</td><td>1,969</td><td>2,145</td><td>8.2</td></tr> <tr><td>18時～19時</td><td>139</td><td>1,800</td><td>1,939</td><td>7.2</td></tr> <tr><td>19時～20時</td><td>124</td><td>1,580</td><td>1,704</td><td>7.3</td></tr> <tr><td>20時～21時</td><td>90</td><td>1,394</td><td>1,484</td><td>6.1</td></tr> <tr><td>21時～22時</td><td>75</td><td>1,229</td><td>1,304</td><td>5.8</td></tr> <tr><td>22時～23時</td><td>59</td><td>1,021</td><td>1,080</td><td>5.5</td></tr> <tr><td>計</td><td>3,232</td><td>24,516</td><td>27,748</td><td>11.6</td></tr> </table>				8時～9時	316	1,964	2,280	13.9	9時～10時	313	1,548	1,861	16.8	10時～11時	341	1,615	1,956	17.4	11時～12時	304	1,886	2,190	13.9	12時～13時	270	1,801	2,071	13.0	13時～14時	276	1,671	1,947	14.2	14時～15時	295	1,561	1,856	15.9	15時～16時	250	1,532	1,782	14.0	16時～17時	204	1,945	2,149	9.5	17時～18時	176	1,969	2,145	8.2	18時～19時	139	1,800	1,939	7.2	19時～20時	124	1,580	1,704	7.3	20時～21時	90	1,394	1,484	6.1	21時～22時	75	1,229	1,304	5.8	22時～23時	59	1,021	1,080	5.5	計	3,232	24,516	27,748	11.6
8時～9時	316	1,964	2,280	13.9																																																																																
9時～10時	313	1,548	1,861	16.8																																																																																
10時～11時	341	1,615	1,956	17.4																																																																																
11時～12時	304	1,886	2,190	13.9																																																																																
12時～13時	270	1,801	2,071	13.0																																																																																
13時～14時	276	1,671	1,947	14.2																																																																																
14時～15時	295	1,561	1,856	15.9																																																																																
15時～16時	250	1,532	1,782	14.0																																																																																
16時～17時	204	1,945	2,149	9.5																																																																																
17時～18時	176	1,969	2,145	8.2																																																																																
18時～19時	139	1,800	1,939	7.2																																																																																
19時～20時	124	1,580	1,704	7.3																																																																																
20時～21時	90	1,394	1,484	6.1																																																																																
21時～22時	75	1,229	1,304	5.8																																																																																
22時～23時	59	1,021	1,080	5.5																																																																																
計	3,232	24,516	27,748	11.6																																																																																

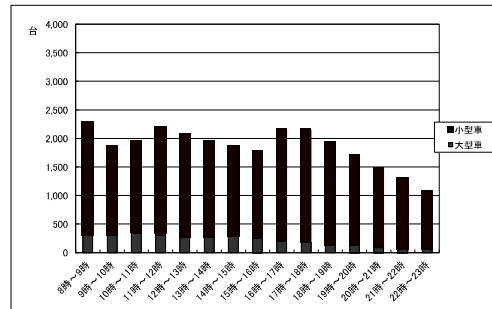

地点	No.4																																																																																																																																																																																																																																																																																																																																	
調査日	令和7年10月27日(月)																																																																																																																																																																																																																																																																																																																																	
天候	曇り																																																																																																																																																																																																																																																																																																																																	
概要	当交差点の交通量ピークは9時～10時であった。																																																																																																																																																																																																																																																																																																																																	
調査方向区分	AからDへ右折 方向1			AからCへ直進 方向2			AからBへ左折 方向3			BからAへ右折 方向4			BからDへ直進 方向5			BからCへ左折 方向6																																																																																																																																																																																																																																																																																																																		
車両区分	大型車	小型車	合計	大型車	小型車	合計	大型車	小型車	合計	大型車	小型車	合計	大型車	小型車	合計	大型車	小型車	合計																																																																																																																																																																																																																																																																																																																
時刻	<table border="1"> <tr><td>8時～9時</td><td>2</td><td>54</td><td>56</td><td>101</td><td>648</td><td>749</td><td>6</td><td>46</td><td>52</td><td>1</td><td>42</td><td>43</td><td>0</td><td>176</td><td>176</td><td>1</td><td>62</td><td>63</td></tr> <tr><td>9時～10時</td><td>1</td><td>68</td><td>69</td><td>121</td><td>577</td><td>698</td><td>3</td><td>49</td><td>52</td><td>0</td><td>59</td><td>59</td><td>1</td><td>171</td><td>172</td><td>3</td><td>77</td><td>80</td></tr> <tr><td>10時～11時</td><td>4</td><td>70</td><td>74</td><td>138</td><td>424</td><td>562</td><td>1</td><td>50</td><td>51</td><td>2</td><td>70</td><td>72</td><td>2</td><td>168</td><td>170</td><td>2</td><td>84</td><td>86</td></tr> <tr><td>11時～12時</td><td>2</td><td>40</td><td>42</td><td>130</td><td>328</td><td>458</td><td>2</td><td>58</td><td>60</td><td>0</td><td>46</td><td>46</td><td>2</td><td>116</td><td>118</td><td>2</td><td>66</td><td>68</td></tr> <tr><td>12時～13時</td><td>3</td><td>37</td><td>40</td><td>116</td><td>337</td><td>453</td><td>3</td><td>49</td><td>52</td><td>4</td><td>55</td><td>59</td><td>1</td><td>132</td><td>133</td><td>0</td><td>71</td><td>71</td></tr> <tr><td>13時～14時</td><td>2</td><td>49</td><td>51</td><td>90</td><td>366</td><td>456</td><td>2</td><td>41</td><td>43</td><td>1</td><td>41</td><td>42</td><td>0</td><td>120</td><td>120</td><td>1</td><td>88</td><td>89</td></tr> <tr><td>14時～15時</td><td>1</td><td>44</td><td>45</td><td>81</td><td>350</td><td>431</td><td>2</td><td>42</td><td>44</td><td>0</td><td>37</td><td>37</td><td>1</td><td>109</td><td>110</td><td>1</td><td>69</td><td>70</td></tr> <tr><td>15時～16時</td><td>0</td><td>41</td><td>41</td><td>66</td><td>341</td><td>407</td><td>0</td><td>39</td><td>39</td><td>2</td><td>29</td><td>31</td><td>2</td><td>99</td><td>101</td><td>0</td><td>44</td><td>44</td></tr> <tr><td>16時～17時</td><td>1</td><td>56</td><td>57</td><td>61</td><td>298</td><td>359</td><td>1</td><td>38</td><td>39</td><td>0</td><td>22</td><td>22</td><td>1</td><td>83</td><td>84</td><td>1</td><td>58</td><td>59</td></tr> <tr><td>17時～18時</td><td>0</td><td>50</td><td>50</td><td>58</td><td>324</td><td>382</td><td>0</td><td>33</td><td>33</td><td>1</td><td>27</td><td>28</td><td>1</td><td>86</td><td>87</td><td>0</td><td>41</td><td>41</td></tr> <tr><td>18時～19時</td><td>0</td><td>55</td><td>55</td><td>51</td><td>240</td><td>291</td><td>0</td><td>40</td><td>40</td><td>1</td><td>26</td><td>27</td><td>2</td><td>92</td><td>94</td><td>1</td><td>38</td><td>39</td></tr> <tr><td>19時～20時</td><td>1</td><td>48</td><td>49</td><td>39</td><td>188</td><td>227</td><td>1</td><td>38</td><td>39</td><td>0</td><td>30</td><td>30</td><td>0</td><td>71</td><td>71</td><td>1</td><td>40</td><td>41</td></tr> <tr><td>20時～21時</td><td>0</td><td>41</td><td>41</td><td>30</td><td>164</td><td>194</td><td>1</td><td>32</td><td>33</td><td>1</td><td>21</td><td>22</td><td>1</td><td>65</td><td>66</td><td>0</td><td>45</td><td>45</td></tr> <tr><td>21時～22時</td><td>0</td><td>34</td><td>34</td><td>26</td><td>141</td><td>167</td><td>0</td><td>27</td><td>27</td><td>0</td><td>17</td><td>17</td><td>1</td><td>48</td><td>49</td><td>0</td><td>39</td><td>39</td></tr> <tr><td>22時～23時</td><td>1</td><td>25</td><td>26</td><td>12</td><td>120</td><td>132</td><td>0</td><td>20</td><td>20</td><td>0</td><td>13</td><td>13</td><td>0</td><td>40</td><td>40</td><td>1</td><td>32</td><td>33</td></tr> <tr><td>計</td><td>18</td><td>712</td><td>730</td><td>1,120</td><td>4,846</td><td>5,966</td><td>22</td><td>602</td><td>624</td><td>13</td><td>535</td><td>548</td><td>15</td><td>1,576</td><td>1,591</td><td>14</td><td>854</td><td>868</td></tr> </table>																		8時～9時	2	54	56	101	648	749	6	46	52	1	42	43	0	176	176	1	62	63	9時～10時	1	68	69	121	577	698	3	49	52	0	59	59	1	171	172	3	77	80	10時～11時	4	70	74	138	424	562	1	50	51	2	70	72	2	168	170	2	84	86	11時～12時	2	40	42	130	328	458	2	58	60	0	46	46	2	116	118	2	66	68	12時～13時	3	37	40	116	337	453	3	49	52	4	55	59	1	132	133	0	71	71	13時～14時	2	49	51	90	366	456	2	41	43	1	41	42	0	120	120	1	88	89	14時～15時	1	44	45	81	350	431	2	42	44	0	37	37	1	109	110	1	69	70	15時～16時	0	41	41	66	341	407	0	39	39	2	29	31	2	99	101	0	44	44	16時～17時	1	56	57	61	298	359	1	38	39	0	22	22	1	83	84	1	58	59	17時～18時	0	50	50	58	324	382	0	33	33	1	27	28	1	86	87	0	41	41	18時～19時	0	55	55	51	240	291	0	40	40	1	26	27	2	92	94	1	38	39	19時～20時	1	48	49	39	188	227	1	38	39	0	30	30	0	71	71	1	40	41	20時～21時	0	41	41	30	164	194	1	32	33	1	21	22	1	65	66	0	45	45	21時～22時	0	34	34	26	141	167	0	27	27	0	17	17	1	48	49	0	39	39	22時～23時	1	25	26	12	120	132	0	20	20	0	13	13	0	40	40	1	32	33	計	18	712	730	1,120	4,846	5,966	22	602	624	13	535	548	15	1,576	1,591	14	854	868
8時～9時	2	54	56	101	648	749	6	46	52	1	42	43	0	176	176	1	62	63																																																																																																																																																																																																																																																																																																																
9時～10時	1	68	69	121	577	698	3	49	52	0	59	59	1	171	172	3	77	80																																																																																																																																																																																																																																																																																																																
10時～11時	4	70	74	138	424	562	1	50	51	2	70	72	2	168	170	2	84	86																																																																																																																																																																																																																																																																																																																
11時～12時	2	40	42	130	328	458	2	58	60	0	46	46	2	116	118	2	66	68																																																																																																																																																																																																																																																																																																																
12時～13時	3	37	40	116	337	453	3	49	52	4	55	59	1	132	133	0	71	71																																																																																																																																																																																																																																																																																																																
13時～14時	2	49	51	90	366	456	2	41	43	1	41	42	0	120	120	1	88	89																																																																																																																																																																																																																																																																																																																
14時～15時	1	44	45	81	350	431	2	42	44	0	37	37	1	109	110	1	69	70																																																																																																																																																																																																																																																																																																																
15時～16時	0	41	41	66	341	407	0	39	39	2	29	31	2	99	101	0	44	44																																																																																																																																																																																																																																																																																																																
16時～17時	1	56	57	61	298	359	1	38	39	0	22	22	1	83	84	1	58	59																																																																																																																																																																																																																																																																																																																
17時～18時	0	50	50	58	324	382	0	33	33	1	27	28	1	86	87	0	41	41																																																																																																																																																																																																																																																																																																																
18時～19時	0	55	55	51	240	291	0	40	40	1	26	27	2	92	94	1	38	39																																																																																																																																																																																																																																																																																																																
19時～20時	1	48	49	39	188	227	1	38	39	0	30	30	0	71	71	1	40	41																																																																																																																																																																																																																																																																																																																
20時～21時	0	41	41	30	164	194	1	32	33	1	21	22	1	65	66	0	45	45																																																																																																																																																																																																																																																																																																																
21時～22時	0	34	34	26	141	167	0	27	27	0	17	17	1	48	49	0	39	39																																																																																																																																																																																																																																																																																																																
22時～23時	1	25	26	12	120	132	0	20	20	0	13	13	0	40	40	1	32	33																																																																																																																																																																																																																																																																																																																
計	18	712	730	1,120	4,846	5,966	22	602	624	13	535	548	15	1,576	1,591	14	854	868																																																																																																																																																																																																																																																																																																																

調査方向区分	CからBへ右折 方向7			CからAへ直進 方向8			CからDへ左折 方向9			DからCへ右折 方向10			DからBへ直進 方向11			DからAへ左折 方向12																																																																																																																																																																																																																																																																																																																		
車両区分	大型車	小型車	合計	大型車	小型車	合計	大型車	小型車	合計	大型車	小型車	合計	大型車	小型車	合計	大型車	小型車	合計																																																																																																																																																																																																																																																																																																																
時刻	<table border="1"> <tr><td>8時～9時</td><td>2</td><td>123</td><td>125</td><td>121</td><td>322</td><td>443</td><td>1</td><td>20</td><td>21</td><td>2</td><td>30</td><td>32</td><td>8</td><td>212</td><td>220</td><td>1</td><td>52</td><td>53</td></tr> <tr><td>9時～10時</td><td>1</td><td>104</td><td>105</td><td>144</td><td>339</td><td>483</td><td>0</td><td>34</td><td>34</td><td>1</td><td>42</td><td>43</td><td>6</td><td>199</td><td>205</td><td>0</td><td>60</td><td>60</td></tr> <tr><td>10時～11時</td><td>4</td><td>72</td><td>76</td><td>161</td><td>312</td><td>473</td><td>1</td><td>46</td><td>47</td><td>2</td><td>54</td><td>56</td><td>8</td><td>174</td><td>182</td><td>0</td><td>78</td><td>78</td></tr> <tr><td>11時～12時</td><td>2</td><td>48</td><td>50</td><td>162</td><td>256</td><td>418</td><td>0</td><td>18</td><td>18</td><td>0</td><td>48</td><td>48</td><td>4</td><td>126</td><td>130</td><td>0</td><td>32</td><td>32</td></tr> <tr><td>12時～13時</td><td>3</td><td>55</td><td>58</td><td>131</td><td>273</td><td>404</td><td>1</td><td>17</td><td>18</td><td>1</td><td>50</td><td>51</td><td>5</td><td>138</td><td>143</td><td>1</td><td>39</td><td>40</td></tr> <tr><td>13時～14時</td><td>3</td><td>60</td><td>63</td><td>119</td><td>232</td><td>351</td><td>1</td><td>24</td><td>25</td><td>1</td><td>45</td><td>46</td><td>4</td><td>121</td><td>125</td><td>2</td><td>54</td><td>56</td></tr> <tr><td>14時～15時</td><td>2</td><td>52</td><td>54</td><td>77</td><td>258</td><td>335</td><td>0</td><td>29</td><td>29</td><td>2</td><td>41</td><td>43</td><td>5</td><td>105</td><td>110</td><td>1</td><td>41</td><td>42</td></tr> <tr><td>15時～16時</td><td>3</td><td>61</td><td>64</td><td>54</td><td>241</td><td>295</td><td>0</td><td>37</td><td>37</td><td>0</td><td>37</td><td>37</td><td>3</td><td>102</td><td>105</td><td>4</td><td>39</td><td>43</td></tr> <tr><td>16時～17時</td><td>1</td><td>59</td><td>60</td><td>57</td><td>229</td><td>286</td><td>1</td><td>33</td><td>34</td><td>1</td><td>35</td><td>36</td><td>4</td><td>99</td><td>103</td><td>3</td><td>44</td><td>47</td></tr> <tr><td>17時～18時</td><td>2</td><td>48</td><td>50</td><td>48</td><td>184</td><td>232</td><td>0</td><td>21</td><td>21</td><td>0</td><td>40</td><td>40</td><td>3</td><td>116</td><td>119</td><td>2</td><td>32</td><td>34</td></tr> <tr><td>18時～19時</td><td>2</td><td>55</td><td>57</td><td>44</td><td>166</td><td>210</td><td>0</td><td>16</td><td>16</td><td>0</td><td>39</td><td>39</td><td>2</td><td>87</td><td>89</td><td>2</td><td>27</td><td>29</td></tr> <tr><td>19時～20時</td><td>3</td><td>37</td><td>40</td><td>30</td><td>150</td><td>180</td><td>0</td><td>13</td><td>13</td><td>1</td><td>35</td><td>36</td><td>3</td><td>66</td><td>69</td><td>1</td><td>21</td><td>22</td></tr> <tr><td>20時～21時</td><td>1</td><td>32</td><td>33</td><td>35</td><td>138</td><td>173</td><td>1</td><td>17</td><td>18</td><td>0</td><td>32</td><td>32</td><td>2</td><td>40</td><td>42</td><td>0</td><td>18</td><td>18</td></tr> <tr><td>21時～22時</td><td>2</td><td>30</td><td>32</td><td>28</td><td>91</td><td>119</td><td>0</td><td>10</td><td>10</td><td>0</td><td>28</td><td>28</td><td>2</td><td>37</td><td>39</td><td>0</td><td>14</td><td>14</td></tr> <tr><td>22時～23時</td><td>1</td><td>22</td><td>23</td><td>21</td><td>74</td><td>95</td><td>0</td><td>7</td><td>7</td><td>0</td><td>22</td><td>22</td><td>1</td><td>32</td><td>33</td><td>1</td><td>12</td><td>13</td></tr> <tr><td>計</td><td>32</td><td>858</td><td>890</td><td>1,232</td><td>3,265</td><td>4,497</td><td>6</td><td>342</td><td>348</td><td>11</td><td>578</td><td>589</td><td>60</td><td>1,654</td><td>1,714</td><td>18</td><td>563</td><td>581</td></tr> </table>																		8時～9時	2	123	125	121	322	443	1	20	21	2	30	32	8	212	220	1	52	53	9時～10時	1	104	105	144	339	483	0	34	34	1	42	43	6	199	205	0	60	60	10時～11時	4	72	76	161	312	473	1	46	47	2	54	56	8	174	182	0	78	78	11時～12時	2	48	50	162	256	418	0	18	18	0	48	48	4	126	130	0	32	32	12時～13時	3	55	58	131	273	404	1	17	18	1	50	51	5	138	143	1	39	40	13時～14時	3	60	63	119	232	351	1	24	25	1	45	46	4	121	125	2	54	56	14時～15時	2	52	54	77	258	335	0	29	29	2	41	43	5	105	110	1	41	42	15時～16時	3	61	64	54	241	295	0	37	37	0	37	37	3	102	105	4	39	43	16時～17時	1	59	60	57	229	286	1	33	34	1	35	36	4	99	103	3	44	47	17時～18時	2	48	50	48	184	232	0	21	21	0	40	40	3	116	119	2	32	34	18時～19時	2	55	57	44	166	210	0	16	16	0	39	39	2	87	89	2	27	29	19時～20時	3	37	40	30	150	180	0	13	13	1	35	36	3	66	69	1	21	22	20時～21時	1	32	33	35	138	173	1	17	18	0	32	32	2	40	42	0	18	18	21時～22時	2	30	32	28	91	119	0	10	10	0	28	28	2	37	39	0	14	14	22時～23時	1	22	23	21	74	95	0	7	7	0	22	22	1	32	33	1	12	13	計	32	858	890	1,232	3,265	4,497	6	342	348	11	578	589	60	1,654	1,714	18	563	581
8時～9時	2	123	125	121	322	443	1	20	21	2	30	32	8	212	220	1	52	53																																																																																																																																																																																																																																																																																																																
9時～10時	1	104	105	144	339	483	0	34	34	1	42	43	6	199	205	0	60	60																																																																																																																																																																																																																																																																																																																
10時～11時	4	72	76	161	312	473	1	46	47	2	54	56	8	174	182	0	78	78																																																																																																																																																																																																																																																																																																																
11時～12時	2	48	50	162	256	418	0	18	18	0	48	48	4	126	130	0	32	32																																																																																																																																																																																																																																																																																																																
12時～13時	3	55	58	131	273	404	1	17	18	1	50	51	5	138	143	1	39	40																																																																																																																																																																																																																																																																																																																
13時～14時	3	60	63	119	232	351	1	24	25	1	45	46	4	121	125	2	54	56																																																																																																																																																																																																																																																																																																																
14時～15時	2	52	54	77	258	335	0	29	29	2	41	43	5	105	110	1	41	42																																																																																																																																																																																																																																																																																																																
15時～16時	3	61	64	54	241	295	0	37	37	0	37	37	3	102	105	4	39	43																																																																																																																																																																																																																																																																																																																
16時～17時	1	59	60	57	229	286	1	33	34	1	35	36	4	99	103	3	44	47																																																																																																																																																																																																																																																																																																																
17時～18時	2	48	50	48	184	232	0	21	21	0	40	40	3	116	119	2	32	34																																																																																																																																																																																																																																																																																																																
18時～19時	2	55	57	44	166	210	0	16	16	0	39	39	2	87	89	2	27	29																																																																																																																																																																																																																																																																																																																
19時～20時	3	37	40	30	150	180	0	13	13	1	35	36	3	66	69	1	21	22																																																																																																																																																																																																																																																																																																																
20時～21時	1	32	33	35	138	173	1	17	18	0	32	32	2	40	42	0	18	18																																																																																																																																																																																																																																																																																																																
21時～22時	2	30	32	28	91	119	0	10	10	0	28	28	2	37	39	0	14	14																																																																																																																																																																																																																																																																																																																
22時～23時	1	22	23	21	74	95	0	7	7	0	22	22	1	32	33	1	12	13																																																																																																																																																																																																																																																																																																																
計	32	858	890	1,232	3,265	4,497	6	342	348	11	578	589	60	1,654	1,714	18	563	581																																																																																																																																																																																																																																																																																																																

調査方向区分	全方向																																																																																			
車両区分	大型車	小型車	合計	大型車混入率(%)																																																																																
時刻	<table border="1"> <tr><td>8時～9時</td><td>246</td><td>1,787</td><td>2,033</td><td>12.1</td></tr> <tr><td>9時～10時</td><td>281</td><td>1,779</td><td>2,060</td><td>13.6</td></tr> <tr><td>10時～11時</td><td>325</td><td>1,602</td><td>1,927</td><td>16.9</td></tr> <tr><td>11時～12時</td><td>306</td><td>1,182</td><td>1,488</td><td>20.6</td></tr> <tr><td>12時～13時</td><td>269</td><td>1,253</td><td>1,522</td><td>17.7</td></tr> <tr><td>13時～14時</td><td>226</td><td>1,241</td><td>1,467</td><td>15.4</td></tr> <tr><td>14時～15時</td><td>173</td><td>1,177</td><td>1,350</td><td>12.8</td></tr> <tr><td>15時～16時</td><td>134</td><td>1,110</td><td>1,244</td><td>10.8</td></tr> <tr><td>16時～17時</td><td>132</td><td>1,054</td><td>1,186</td><td>11.1</td></tr> <tr><td>17時～18時</td><td>115</td><td>1,002</td><td>1,117</td><td>10.3</td></tr> <tr><td>18時～19時</td><td>105</td><td>881</td><td>986</td><td>10.6</td></tr> <tr><td>19時～20時</td><td>80</td><td>737</td><td>817</td><td>9.8</td></tr> <tr><td>20時～21時</td><td>72</td><td>645</td><td>717</td><td>10.0</td></tr> <tr><td>21時～22時</td><td>59</td><td>516</td><td>575</td><td>10.3</td></tr> <tr><td>22時～23時</td><td>38</td><td>419</td><td>457</td><td>8.3</td></tr> <tr><td>計</td><td>2,561</td><td>16,385</td><td>18,946</td><td>13.5</td></tr> </table>				8時～9時	246	1,787	2,033	12.1	9時～10時	281	1,779	2,060	13.6	10時～11時	325	1,602	1,927	16.9	11時～12時	306	1,182	1,488	20.6	12時～13時	269	1,253	1,522	17.7	13時～14時	226	1,241	1,467	15.4	14時～15時	173	1,177	1,350	12.8	15時～16時	134	1,110	1,244	10.8	16時～17時	132	1,054	1,186	11.1	17時～18時	115	1,002	1,117	10.3	18時～19時	105	881	986	10.6	19時～20時	80	737	817	9.8	20時～21時	72	645	717	10.0	21時～22時	59	516	575	10.3	22時～23時	38	419	457	8.3	計	2,561	16,385	18,946	13.5
8時～9時	246	1,787	2,033	12.1																																																																																
9時～10時	281	1,779	2,060	13.6																																																																																
10時～11時	325	1,602	1,927	16.9																																																																																
11時～12時	306	1,182	1,488	20.6																																																																																
12時～13時	269	1,253	1,522	17.7																																																																																
13時～14時	226	1,241	1,467	15.4																																																																																
14時～15時	173	1,177	1,350	12.8																																																																																
15時～16時	134	1,110	1,244	10.8																																																																																
16時～17時	132	1,054	1,186	11.1																																																																																
17時～18時	115	1,002	1,117	10.3																																																																																
18時～19時	105	881	986	10.6																																																																																
19時～20時	80	737	817	9.8																																																																																
20時～21時	72	645	717	10.0																																																																																
21時～22時	59	516	575	10.3																																																																																
22時～23時	38	419	457	8.3																																																																																
計	2,561	16,385	18,946	13.5																																																																																

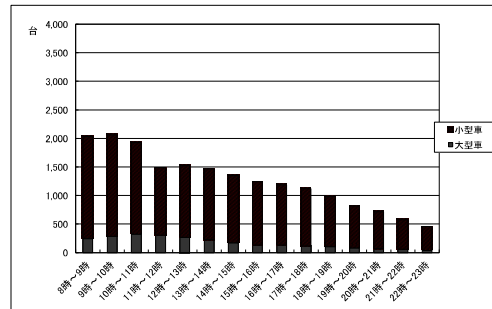

地点	No.5																																																																																																																																																																																																																																																																																																																																	
調査日	令和7年10月27日(月)																																																																																																																																																																																																																																																																																																																																	
天候	曇り																																																																																																																																																																																																																																																																																																																																	
概要	当交差点の交通量ピークは8時～9時であった。																																																																																																																																																																																																																																																																																																																																	
調査方向区分	AからDへ右折 方向1			AからCへ直進 方向2			AからBへ左折 方向3			BからAへ右折 方向4			BからDへ直進 方向5			BからCへ左折 方向6																																																																																																																																																																																																																																																																																																																		
車両区分	大型車	小型車	合計	大型車	小型車	合計	大型車	小型車	合計	大型車	小型車	合計	大型車	小型車	合計	大型車	小型車	合計																																																																																																																																																																																																																																																																																																																
時刻	<table border="1"> <tr><td>8時～9時</td><td>3</td><td>70</td><td>73</td><td>60</td><td>377</td><td>437</td><td>2</td><td>19</td><td>21</td><td>1</td><td>37</td><td>38</td><td>3</td><td>298</td><td>301</td><td>0</td><td>39</td><td>39</td></tr> <tr><td>9時～10時</td><td>2</td><td>88</td><td>90</td><td>54</td><td>360</td><td>414</td><td>2</td><td>20</td><td>22</td><td>0</td><td>28</td><td>28</td><td>1</td><td>270</td><td>271</td><td>1</td><td>58</td><td>59</td></tr> <tr><td>10時～11時</td><td>6</td><td>64</td><td>70</td><td>47</td><td>298</td><td>345</td><td>3</td><td>25</td><td>28</td><td>1</td><td>20</td><td>21</td><td>3</td><td>234</td><td>237</td><td>0</td><td>50</td><td>50</td></tr> <tr><td>11時～12時</td><td>10</td><td>69</td><td>79</td><td>36</td><td>212</td><td>248</td><td>1</td><td>18</td><td>19</td><td>1</td><td>14</td><td>15</td><td>2</td><td>172</td><td>174</td><td>0</td><td>54</td><td>54</td></tr> <tr><td>12時～13時</td><td>6</td><td>54</td><td>60</td><td>33</td><td>205</td><td>238</td><td>0</td><td>16</td><td>16</td><td>0</td><td>19</td><td>19</td><td>0</td><td>170</td><td>170</td><td>1</td><td>48</td><td>49</td></tr> <tr><td>13時～14時</td><td>5</td><td>55</td><td>60</td><td>29</td><td>233</td><td>262</td><td>2</td><td>19</td><td>21</td><td>1</td><td>17</td><td>18</td><td>3</td><td>188</td><td>191</td><td>0</td><td>49</td><td>49</td></tr> <tr><td>14時～15時</td><td>4</td><td>47</td><td>51</td><td>22</td><td>258</td><td>280</td><td>1</td><td>22</td><td>23</td><td>0</td><td>16</td><td>16</td><td>2</td><td>176</td><td>178</td><td>1</td><td>40</td><td>41</td></tr> <tr><td>15時～16時</td><td>4</td><td>50</td><td>54</td><td>26</td><td>241</td><td>267</td><td>2</td><td>21</td><td>23</td><td>1</td><td>11</td><td>12</td><td>2</td><td>193</td><td>195</td><td>1</td><td>43</td><td>44</td></tr> <tr><td>16時～17時</td><td>3</td><td>59</td><td>62</td><td>32</td><td>213</td><td>245</td><td>0</td><td>16</td><td>16</td><td>1</td><td>14</td><td>15</td><td>4</td><td>181</td><td>185</td><td>0</td><td>38</td><td>38</td></tr> <tr><td>17時～18時</td><td>5</td><td>46</td><td>51</td><td>33</td><td>226</td><td>259</td><td>2</td><td>14</td><td>16</td><td>0</td><td>19</td><td>19</td><td>2</td><td>165</td><td>167</td><td>1</td><td>51</td><td>52</td></tr> <tr><td>18時～19時</td><td>3</td><td>42</td><td>45</td><td>27</td><td>201</td><td>228</td><td>2</td><td>20</td><td>22</td><td>1</td><td>18</td><td>19</td><td>1</td><td>161</td><td>162</td><td>1</td><td>55</td><td>56</td></tr> <tr><td>19時～20時</td><td>2</td><td>38</td><td>40</td><td>22</td><td>184</td><td>206</td><td>1</td><td>15</td><td>16</td><td>0</td><td>15</td><td>15</td><td>3</td><td>149</td><td>152</td><td>1</td><td>43</td><td>44</td></tr> <tr><td>20時～21時</td><td>3</td><td>34</td><td>37</td><td>17</td><td>166</td><td>183</td><td>2</td><td>12</td><td>14</td><td>1</td><td>14</td><td>15</td><td>1</td><td>120</td><td>121</td><td>2</td><td>37</td><td>39</td></tr> <tr><td>21時～22時</td><td>2</td><td>26</td><td>28</td><td>15</td><td>149</td><td>164</td><td>1</td><td>11</td><td>12</td><td>1</td><td>11</td><td>12</td><td>2</td><td>114</td><td>116</td><td>0</td><td>31</td><td>31</td></tr> <tr><td>22時～23時</td><td>1</td><td>21</td><td>22</td><td>13</td><td>121</td><td>134</td><td>0</td><td>8</td><td>8</td><td>0</td><td>8</td><td>8</td><td>1</td><td>89</td><td>90</td><td>0</td><td>18</td><td>18</td></tr> <tr><td>計</td><td>59</td><td>763</td><td>822</td><td>466</td><td>3,444</td><td>3,910</td><td>21</td><td>256</td><td>277</td><td>9</td><td>261</td><td>270</td><td>30</td><td>2,680</td><td>2,710</td><td>9</td><td>654</td><td>663</td></tr> </table>																		8時～9時	3	70	73	60	377	437	2	19	21	1	37	38	3	298	301	0	39	39	9時～10時	2	88	90	54	360	414	2	20	22	0	28	28	1	270	271	1	58	59	10時～11時	6	64	70	47	298	345	3	25	28	1	20	21	3	234	237	0	50	50	11時～12時	10	69	79	36	212	248	1	18	19	1	14	15	2	172	174	0	54	54	12時～13時	6	54	60	33	205	238	0	16	16	0	19	19	0	170	170	1	48	49	13時～14時	5	55	60	29	233	262	2	19	21	1	17	18	3	188	191	0	49	49	14時～15時	4	47	51	22	258	280	1	22	23	0	16	16	2	176	178	1	40	41	15時～16時	4	50	54	26	241	267	2	21	23	1	11	12	2	193	195	1	43	44	16時～17時	3	59	62	32	213	245	0	16	16	1	14	15	4	181	185	0	38	38	17時～18時	5	46	51	33	226	259	2	14	16	0	19	19	2	165	167	1	51	52	18時～19時	3	42	45	27	201	228	2	20	22	1	18	19	1	161	162	1	55	56	19時～20時	2	38	40	22	184	206	1	15	16	0	15	15	3	149	152	1	43	44	20時～21時	3	34	37	17	166	183	2	12	14	1	14	15	1	120	121	2	37	39	21時～22時	2	26	28	15	149	164	1	11	12	1	11	12	2	114	116	0	31	31	22時～23時	1	21	22	13	121	134	0	8	8	0	8	8	1	89	90	0	18	18	計	59	763	822	466	3,444	3,910	21	256	277	9	261	270	30	2,680	2,710	9	654	663
8時～9時	3	70	73	60	377	437	2	19	21	1	37	38	3	298	301	0	39	39																																																																																																																																																																																																																																																																																																																
9時～10時	2	88	90	54	360	414	2	20	22	0	28	28	1	270	271	1	58	59																																																																																																																																																																																																																																																																																																																
10時～11時	6	64	70	47	298	345	3	25	28	1	20	21	3	234	237	0	50	50																																																																																																																																																																																																																																																																																																																
11時～12時	10	69	79	36	212	248	1	18	19	1	14	15	2	172	174	0	54	54																																																																																																																																																																																																																																																																																																																
12時～13時	6	54	60	33	205	238	0	16	16	0	19	19	0	170	170	1	48	49																																																																																																																																																																																																																																																																																																																
13時～14時	5	55	60	29	233	262	2	19	21	1	17	18	3	188	191	0	49	49																																																																																																																																																																																																																																																																																																																
14時～15時	4	47	51	22	258	280	1	22	23	0	16	16	2	176	178	1	40	41																																																																																																																																																																																																																																																																																																																
15時～16時	4	50	54	26	241	267	2	21	23	1	11	12	2	193	195	1	43	44																																																																																																																																																																																																																																																																																																																
16時～17時	3	59	62	32	213	245	0	16	16	1	14	15	4	181	185	0	38	38																																																																																																																																																																																																																																																																																																																
17時～18時	5	46	51	33	226	259	2	14	16	0	19	19	2	165	167	1	51	52																																																																																																																																																																																																																																																																																																																
18時～19時	3	42	45	27	201	228	2	20	22	1	18	19	1	161	162	1	55	56																																																																																																																																																																																																																																																																																																																
19時～20時	2	38	40	22	184	206	1	15	16	0	15	15	3	149	152	1	43	44																																																																																																																																																																																																																																																																																																																
20時～21時	3	34	37	17	166	183	2	12	14	1	14	15	1	120	121	2	37	39																																																																																																																																																																																																																																																																																																																
21時～22時	2	26	28	15	149	164	1	11	12	1	11	12	2	114	116	0	31	31																																																																																																																																																																																																																																																																																																																
22時～23時	1	21	22	13	121	134	0	8	8	0	8	8	1	89	90	0	18	18																																																																																																																																																																																																																																																																																																																
計	59	763	822	466	3,444	3,910	21	256	277	9	261	270	30	2,680	2,710	9	654	663																																																																																																																																																																																																																																																																																																																

調査方向区分	CからBへ右折 方向7			CからAへ直進 方向8			CからDへ左折 方向9			DからCへ右折 方向10			DからBへ直進 方向11			DからAへ左折 方向12																																																																																																																																																																																																																																																																																																																		
車両区分	大型車	小型車	合計	大型車	小型車	合計	大型車	小型車	合計	大型車	小型車	合計	大型車	小型車	合計	大型車	小型車	合計																																																																																																																																																																																																																																																																																																																
時刻	<table border="1"> <tr><td>8時～9時</td><td>9</td><td>63</td><td>72</td><td>50</td><td>266</td><td>316</td><td>2</td><td>59</td><td>61</td><td>3</td><td>102</td><td>105</td><td>5</td><td>266</td><td>271</td><td>3</td><td>59</td><td>62</td></tr> <tr><td>9時～10時</td><td>13</td><td>44</td><td>57</td><td>42</td><td>258</td><td>300</td><td>1</td><td>62</td><td>63</td><td>2</td><td>90</td><td>92</td><td>3</td><td>242</td><td>245</td><td>2</td><td>54</td><td>56</td></tr> <tr><td>10時～11時</td><td>7</td><td>39</td><td>46</td><td>48</td><td>250</td><td>298</td><td>0</td><td>68</td><td>68</td><td>1</td><td>88</td><td>89</td><td>4</td><td>198</td><td>202</td><td>1</td><td>59</td><td>60</td></tr> <tr><td>11時～12時</td><td>6</td><td>24</td><td>30</td><td>30</td><td>246</td><td>276</td><td>1</td><td>66</td><td>67</td><td>0</td><td>82</td><td>82</td><td>2</td><td>188</td><td>190</td><td>0</td><td>66</td><td>66</td></tr> <tr><td>12時～13時</td><td>6</td><td>30</td><td>36</td><td>31</td><td>222</td><td>253</td><td>0</td><td>48</td><td>48</td><td>0</td><td>78</td><td>78</td><td>2</td><td>190</td><td>192</td><td>0</td><td>58</td><td>58</td></tr> <tr><td>13時～14時</td><td>8</td><td>29</td><td>37</td><td>32</td><td>239</td><td>271</td><td>1</td><td>49</td><td>50</td><td>1</td><td>71</td><td>72</td><td>5</td><td>213</td><td>218</td><td>1</td><td>67</td><td>68</td></tr> <tr><td>14時～15時</td><td>3</td><td>28</td><td>31</td><td>22</td><td>261</td><td>283</td><td>0</td><td>40</td><td>40</td><td>0</td><td>61</td><td>61</td><td>2</td><td>204</td><td>206</td><td>0</td><td>64</td><td>64</td></tr> <tr><td>15時～16時</td><td>4</td><td>26</td><td>30</td><td>27</td><td>257</td><td>284</td><td>1</td><td>31</td><td>32</td><td>1</td><td>64</td><td>65</td><td>3</td><td>228</td><td>231</td><td>0</td><td>62</td><td>62</td></tr> <tr><td>16時～17時</td><td>2</td><td>30</td><td>32</td><td>21</td><td>249</td><td>270</td><td>1</td><td>33</td><td>34</td><td>2</td><td>77</td><td>79</td><td>2</td><td>211</td><td>213</td><td>1</td><td>70</td><td>71</td></tr> <tr><td>17時～18時</td><td>3</td><td>36</td><td>39</td><td>19</td><td>232</td><td>251</td><td>1</td><td>28</td><td>29</td><td>2</td><td>50</td><td>52</td><td>2</td><td>193</td><td>195</td><td>2</td><td>73</td><td>75</td></tr> <tr><td>18時～19時</td><td>3</td><td>33</td><td>36</td><td>17</td><td>190</td><td>207</td><td>0</td><td>24</td><td>24</td><td>1</td><td>61</td><td>62</td><td>1</td><td>181</td><td>182</td><td>1</td><td>65</td><td>66</td></tr> <tr><td>19時～20時</td><td>2</td><td>28</td><td>30</td><td>14</td><td>184</td><td>198</td><td>0</td><td>27</td><td>27</td><td>2</td><td>55</td><td>57</td><td>3</td><td>190</td><td>193</td><td>1</td><td>54</td><td>55</td></tr> <tr><td>20時～21時</td><td>1</td><td>21</td><td>22</td><td>16</td><td>166</td><td>182</td><td>1</td><td>20</td><td>21</td><td>0</td><td>48</td><td>48</td><td>2</td><td>155</td><td>157</td><td>0</td><td>49</td><td>49</td></tr> <tr><td>21時～22時</td><td>0</td><td>22</td><td>22</td><td>11</td><td>130</td><td>141</td><td>0</td><td>19</td><td>19</td><td>0</td><td>31</td><td>31</td><td>1</td><td>139</td><td>140</td><td>0</td><td>44</td><td>44</td></tr> <tr><td>22時～23時</td><td>1</td><td>13</td><td>14</td><td>8</td><td>83</td><td>91</td><td>0</td><td>13</td><td>13</td><td>1</td><td>28</td><td>29</td><td>2</td><td>104</td><td>106</td><td>1</td><td>32</td><td>33</td></tr> <tr><td>計</td><td>68</td><td>466</td><td>534</td><td>388</td><td>3,233</td><td>3,621</td><td>9</td><td>587</td><td>596</td><td>16</td><td>986</td><td>1,002</td><td>39</td><td>2,902</td><td>2,941</td><td>13</td><td>876</td><td>889</td></tr> </table>																		8時～9時	9	63	72	50	266	316	2	59	61	3	102	105	5	266	271	3	59	62	9時～10時	13	44	57	42	258	300	1	62	63	2	90	92	3	242	245	2	54	56	10時～11時	7	39	46	48	250	298	0	68	68	1	88	89	4	198	202	1	59	60	11時～12時	6	24	30	30	246	276	1	66	67	0	82	82	2	188	190	0	66	66	12時～13時	6	30	36	31	222	253	0	48	48	0	78	78	2	190	192	0	58	58	13時～14時	8	29	37	32	239	271	1	49	50	1	71	72	5	213	218	1	67	68	14時～15時	3	28	31	22	261	283	0	40	40	0	61	61	2	204	206	0	64	64	15時～16時	4	26	30	27	257	284	1	31	32	1	64	65	3	228	231	0	62	62	16時～17時	2	30	32	21	249	270	1	33	34	2	77	79	2	211	213	1	70	71	17時～18時	3	36	39	19	232	251	1	28	29	2	50	52	2	193	195	2	73	75	18時～19時	3	33	36	17	190	207	0	24	24	1	61	62	1	181	182	1	65	66	19時～20時	2	28	30	14	184	198	0	27	27	2	55	57	3	190	193	1	54	55	20時～21時	1	21	22	16	166	182	1	20	21	0	48	48	2	155	157	0	49	49	21時～22時	0	22	22	11	130	141	0	19	19	0	31	31	1	139	140	0	44	44	22時～23時	1	13	14	8	83	91	0	13	13	1	28	29	2	104	106	1	32	33	計	68	466	534	388	3,233	3,621	9	587	596	16	986	1,002	39	2,902	2,941	13	876	889
8時～9時	9	63	72	50	266	316	2	59	61	3	102	105	5	266	271	3	59	62																																																																																																																																																																																																																																																																																																																
9時～10時	13	44	57	42	258	300	1	62	63	2	90	92	3	242	245	2	54	56																																																																																																																																																																																																																																																																																																																
10時～11時	7	39	46	48	250	298	0	68	68	1	88	89	4	198	202	1	59	60																																																																																																																																																																																																																																																																																																																
11時～12時	6	24	30	30	246	276	1	66	67	0	82	82	2	188	190	0	66	66																																																																																																																																																																																																																																																																																																																
12時～13時	6	30	36	31	222	253	0	48	48	0	78	78	2	190	192	0	58	58																																																																																																																																																																																																																																																																																																																
13時～14時	8	29	37	32	239	271	1	49	50	1	71	72	5	213	218	1	67	68																																																																																																																																																																																																																																																																																																																
14時～15時	3	28	31	22	261	283	0	40	40	0	61	61	2	204	206	0	64	64																																																																																																																																																																																																																																																																																																																
15時～16時	4	26	30	27	257	284	1	31	32	1	64	65	3	228	231	0	62	62																																																																																																																																																																																																																																																																																																																
16時～17時	2	30	32	21	249	270	1	33	34	2	77	79	2	211	213	1	70	71																																																																																																																																																																																																																																																																																																																
17時～18時	3	36	39	19	232	251	1	28	29	2	50	52	2	193	195	2	73	75																																																																																																																																																																																																																																																																																																																
18時～19時	3	33	36	17	190	207	0	24	24	1	61	62	1	181	182	1	65	66																																																																																																																																																																																																																																																																																																																
19時～20時	2	28	30	14	184	198	0	27	27	2	55	57	3	190	193	1	54	55																																																																																																																																																																																																																																																																																																																
20時～21時	1	21	22	16	166	182	1	20	21	0	48	48	2	155	157	0	49	49																																																																																																																																																																																																																																																																																																																
21時～22時	0	22	22	11	130	141	0	19	19	0	31	31	1	139	140	0	44	44																																																																																																																																																																																																																																																																																																																
22時～23時	1	13	14	8	83	91	0	13	13	1	28	29	2	104	106	1	32	33																																																																																																																																																																																																																																																																																																																
計	68	466	534	388	3,233	3,621	9	587	596	16	986	1,002	39	2,902	2,941	13	876	889																																																																																																																																																																																																																																																																																																																

調査方向区分	全方向																																																																																			
車両区分	大型車	小型車	合計	大型車混入率(%)																																																																																
時刻	<table border="1"> <tr><td>8時～9時</td><td>141</td><td>1,655</td><td>1,796</td><td>7.9</td></tr> <tr><td>9時～10時</td><td>123</td><td>1,574</td><td>1,697</td><td>7.2</td></tr> <tr><td>10時～11時</td><td>121</td><td>1,393</td><td>1,514</td><td>8.0</td></tr> <tr><td>11時～12時</td><td>89</td><td>1,211</td><td>1,300</td><td>6.8</td></tr> <tr><td>12時～13時</td><td>79</td><td>1,138</td><td>1,217</td><td>6.5</td></tr> <tr><td>13時～14時</td><td>88</td><td>1,229</td><td>1,317</td><td>6.7</td></tr> <tr><td>14時～15時</td><td>57</td><td>1,217</td><td>1,274</td><td>4.5</td></tr> <tr><td>15時～16時</td><td>72</td><td>1,227</td><td>1,299</td><td>5.5</td></tr> <tr><td>16時～17時</td><td>69</td><td>1,191</td><td>1,260</td><td>5.5</td></tr> <tr><td>17時～18時</td><td>72</td><td>1,133</td><td>1,205</td><td>6.0</td></tr> <tr><td>18時～19時</td><td>58</td><td>1,051</td><td>1,109</td><td>5.2</td></tr> <tr><td>19時～20時</td><td>51</td><td>982</td><td>1,033</td><td>4.9</td></tr> <tr><td>20時～21時</td><td>46</td><td>842</td><td>888</td><td>5.2</td></tr> <tr><td>21時～22時</td><td>33</td><td>727</td><td>760</td><td>4.3</td></tr> <tr><td>22時～23時</td><td>28</td><td>538</td><td>566</td><td>4.9</td></tr> <tr><td>計</td><td>1,127</td><td>17,108</td><td>18,235</td><td>6.2</td></tr> </table>				8時～9時	141	1,655	1,796	7.9	9時～10時	123	1,574	1,697	7.2	10時～11時	121	1,393	1,514	8.0	11時～12時	89	1,211	1,300	6.8	12時～13時	79	1,138	1,217	6.5	13時～14時	88	1,229	1,317	6.7	14時～15時	57	1,217	1,274	4.5	15時～16時	72	1,227	1,299	5.5	16時～17時	69	1,191	1,260	5.5	17時～18時	72	1,133	1,205	6.0	18時～19時	58	1,051	1,109	5.2	19時～20時	51	982	1,033	4.9	20時～21時	46	842	888	5.2	21時～22時	33	727	760	4.3	22時～23時	28	538	566	4.9	計	1,127	17,108	18,235	6.2
8時～9時	141	1,655	1,796	7.9																																																																																
9時～10時	123	1,574	1,697	7.2																																																																																
10時～11時	121	1,393	1,514	8.0																																																																																
11時～12時	89	1,211	1,300	6.8																																																																																
12時～13時	79	1,138	1,217	6.5																																																																																
13時～14時	88	1,229	1,317	6.7																																																																																
14時～15時	57	1,217	1,274	4.5																																																																																
15時～16時	72	1,227	1,299	5.5																																																																																
16時～17時	69	1,191	1,260	5.5																																																																																
17時～18時	72	1,133	1,205	6.0																																																																																
18時～19時	58	1,051	1,109	5.2																																																																																
19時～20時	51	982	1,033	4.9																																																																																
20時～21時	46	842	888	5.2																																																																																
21時～22時	33	727	760	4.3																																																																																
22時～23時	28	538	566	4.9																																																																																
計	1,127	17,108	18,235	6.2																																																																																

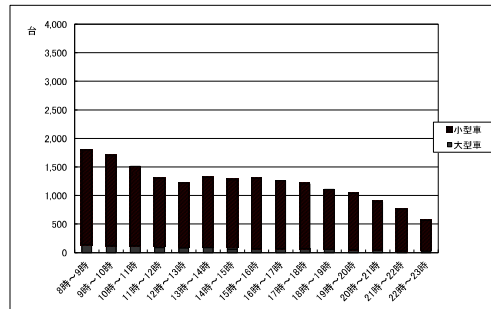

開発発生集中交通量の算出

■計画の概要

店舗面積：1,420㎡（熊谷市人口 189,758人 R8.2.1現在）

■1日自動車発生集中交通量

大規模小売店舗立地法指針の項目を求める算式に準ずる。

1日発生集中交通量

店舗面積当たり
自動車 平均乗車
日来客原単位 1,057.0 × 店舗面積 1,420千㎡ × 分担率 70.0% ÷ 人員 2人

≒ 1日自動車発生交通量：525台

■ピーク自動車発生集中交通量

休日1日自動車発生交通量525台 × ピーク率14.4%

≒ ピーク自動車発生交通量76台

必要駐車台数：平均駐車係数0.63=48台

来店車両ルート別方面比率

商圈は、計画店舗地より半径2kmと想定した。

半径2kmのエリア内の地域を各町丁別に7ルートに分割し算出した。

各ルート別比率は下図、下表に示す。

ルート	世帯数	比率	来店台数
Aルート	2,566	13%	10
Bルート	2,040	10%	7
Cルート	7,116	35%	27
Dルート	2,617	13%	10
Eルート	2,361	11%	8
Fルート	2,082	10%	8
Gルート	1,672	8%	6
合計	20,454	100%	76

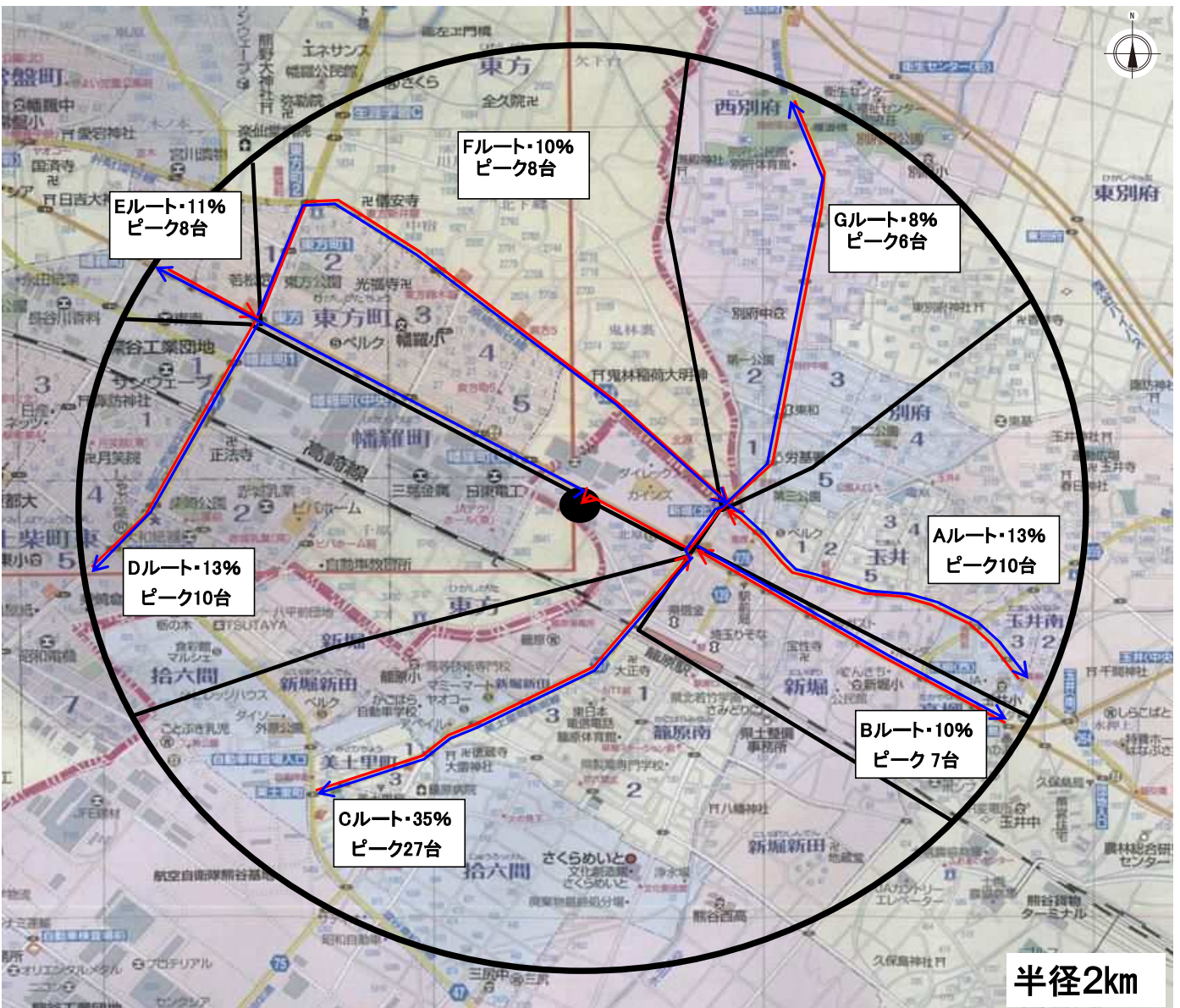

施設完成後交通量（休日）

現況交通量のピーク時に、ピーク時の計画による発生交通量を上乗せし、ピーク時施設完成後交通量とした

流入路A			流入路B		
左	直	右	左	直	右
88	466	90	87	243	63
0	0	0	0	0	0
88	466	90	87	243	63

流入路D			交差点 4			流入路B		
左	直	右	14時台			左	直	右
76	206	62				87	243	63
0	0	0				0	0	0
76	206	62				87	243	63

流入路C		
左	直	右
41	514	70
0	0	76
41	514	146

流入路A			流入路B		
左	直	右	左	直	右
22	242	91	33	223	30
0	6	0	10	0	0
22	248	91	43	223	30

流入路D			交差点 5			流入路B		
左	直	右	15時台			左	直	右
69	255	71				33	223	30
6	10	60				10	0	0
75	265	131				43	223	30

流入路C		
左	直	右
69	212	34
0	0	0
69	212	34

凡例
直
現況交通量
発生交通量
施設完成後交通量

流入路A			流入路B		
左	直	右	左	直	右
50	396	76	100	440	36
0	0	0	10	8	58
50	396	76	110	448	94

流入路D			交差点 3			流入路B		
左	直	右	11時台			左	直	右
32	415	94				100	440	36
8	0	0				10	8	58
40	415	94				110	448	94

流入路C		
左	直	右
70	383	264
0	10	0
70	393	264

流入路A			流入路B		
左	直	右	左	直	右
12	233	74	146	447	36
7	27	42	0	7	0
19	260	116	146	454	36

流入路D			交差点 2			流入路B		
左	直	右	14時台			左	直	右
73	389	144				146	447	36
0	0	0				0	7	0
73	389	144				146	454	36

流入路C		
左	直	右
115	178	99
27	0	0
142	178	99

流入路A			流入路B		
左	直	右	左	直	右
12		221			
0		0			
12		221			

流入路D			交差点 1			流入路B		
直	直		13時台			直		
185	400					506		
0	7					7		
185	407					513		

施設完成後交通量（平日）

現況交通量のピーク時に、ピーク時の計画による発生交通量を上乗せし、ピーク時施設完成後交通量とした

流入路A			交差点 4 9時台			流入路B		
左	直	右				左	直	右
52	698	69				80	172	59
0	0	0				0	0	0
52	698	69	80	172	59			
流入路D			交差点 4 9時台			流入路C		
左	直	右				左	直	右
60	205	43				34	483	105
0	0	0				0	0	76
60	205	43	34	483	181			

流入路A			交差点 5 8時台			流入路B		
左	直	右				左	直	右
21	437	73				39	301	38
0	6	0				10	0	0
21	443	73	49	301	38			
流入路D			交差点 5 8時台			流入路C		
左	直	右				左	直	右
62	271	105				61	316	72
6	10	60				0	0	0
68	281	165	61	316	72			

凡例
直
現況交通量
発生交通量
施設完成後交通量

流入路A			交差点 3 8時台			流入路B		
左	直	右				左	直	右
32	604	84				114	257	40
0	0	0				10	8	58
32	604	84	124	265	98			
流入路D			交差点 3 8時台			流入路C		
左	直	右				左	直	右
20	287	106				79	491	166
8	0	0				0	10	0
28	287	106	79	501	166			

流入路A			交差点 2 14時台			流入路B		
左	直	右				左	直	右
12	297	56				160	410	32
7	27	42				0	7	0
19	324	98	160	417	32			
流入路D			交差点 2 14時台			流入路C		
左	直	右				左	直	右
59	396	118				90	264	156
0	0	0				27	0	0
59	396	118	117	264	156			

流入路A			交差点 1 8時台			流入路B		
左	直	右				左	直	右
13		420						
0		0						
13		420						
流入路D			交差点 1 8時台			流入路B		
直	直					直	直	
340	416							
0	7							
340	423							

計画地周辺交差点、交差点需要率による評価

信号交通量調査地点の評価を交差点飽和度より実施した。

結果は交差点需要率についてはすべての交差点が限界値である0.9を下回る結果である。

交差点1

休日交差点需要率	現況	施設完成後
	0.473	0.477
平日交差点需要率	現況	施設完成後
	0.678	0.681

交差点2

休日交差点需要率	現況	施設完成後
	0.516	0.542
平日交差点需要率	現況	施設完成後
	0.595	0.614

交差点3

休日交差点需要率	現況	施設完成後
	0.544	0.561
平日交差点需要率	現況	施設完成後
	0.475	0.485

交差点4

休日交差点需要率	現況	施設完成後
	0.383	0.412
平日交差点需要率	現況	施設完成後
	0.408	0.530

交差点5

休日交差点需要率	現況	施設完成後
	0.391	0.440
平日交差点需要率	現況	施設完成後
	0.532	0.599



交差点1(久保島) 休日 現況 13時台

流入部	B	D	D'	A			
車線	直	直	直	左	右		
車線数	1	1	1	1	1		
飽和交通流の基本値 S B	2,000	2,000	2,000	1,800	1,800		
車線幅員による補正值 α_w	1.00	1.00	1.00	1.00	1.00		
	m	3.3	3.0	3.0	3.0		
大型車混入による補正值 α_T	1.00	0.99	0.99	0.94	0.97		
	%	0.40	1.00	1.08	8.33	4.52	
左折混入による補正值 α_{LT}	1.00	1.00	1.00	1.00	1.00		
	L %	-	-	-	100.0	-	
有効青時間 G秒	80	80	110	45	-		
右折車混入による補正值 α_{RT}	1.00	1.00	1.00	1.00	1.00		
	(右折率) R %	-	-	-	-	100.0	
(有効青時間) G秒	80	80	110	-	45		
(現示のさげ台数) <台/C	-	-	-	-	-		
飽和交通流率 SA	2,000	1,980	1,980	1,692	1,746		
A : 交通量 q	506	400	185	12	221	現示の飽和度	交差点飽和度
正規化交通量 ρ	0.253	0.202	0.093	0.007	0.127		
必要現示率	1 ϕ	0.253	0.202			0.253	0.473
	2 ϕ				0.007	0.127	
	3 ϕ			0.093		0.093	
	4 ϕ					0.000	
	5 ϕ					0.000	
	6 ϕ					0.000	
B:可能交通容量	1,067	1,104	1,452	508	524		
A/B:混雑度	0.474	0.362	0.127	0.024	0.422		

交差点交通量

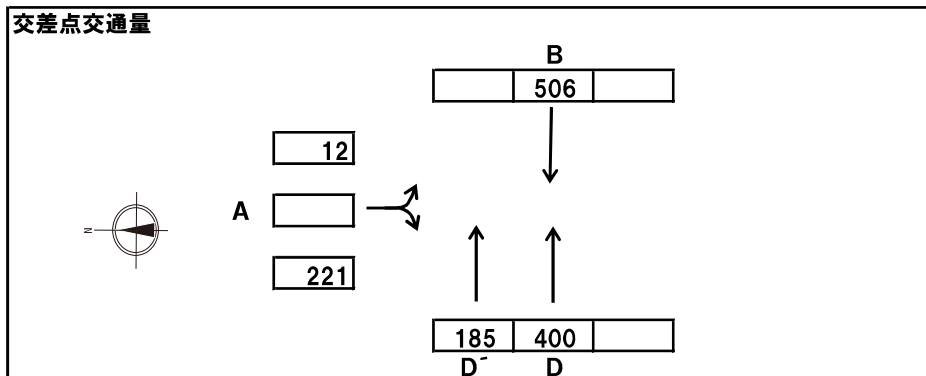

周期	1 ϕ	2 ϕ	3 ϕ	4 ϕ
150	BD青	A青	D'青	
	G 80	G 45	G 110	G

右折⇒信号の変更による通過できる台数

48 台/時・車線

交差点1(久保島) 休日 施設完成後 13時台

流入部	B	D	D'	A			
車線	直	直	直	左	右		
車線数	1	1	1	1	1		
飽和交通流の基本値 SB	2,000	2,000	2,000	1,800	1,800		
車線幅員による補正值 α_w	1.00	1.00	1.00	1.00	1.00		
	m	3.3	3.0	3.0	3.0		
大型車混入による補正值 α_T	1.00	0.99	0.99	0.94	0.97		
	%	0.40	1.00	1.08	8.33	4.52	
左折混入による補正值 α_{LT}	1.00	1.00	1.00	1.00	1.00		
	L %	-	-	-	100.0	-	
有効青時間 G秒	80	80	110	45	-		
右折車混入による補正值 α_{RT}	1.00	1.00	1.00	1.00	1.00		
	(右折率) R %	-	-	-	-	100.0	
(有効青時間) G秒	80	80	110	-	45		
(現示のさげ台数) <台/C	-	-	-	-	-		
飽和交通流率 SA	2,000	1,980	1,980	1,692	1,746		
A : 交通量 q	513	407	185	12	221	現示の飽和度	交差点飽和度
正規化交通量 ρ	0.257	0.206	0.093	0.007	0.127		
必要現示率	1 ϕ	0.257	0.206	-	-	0.257	0.477
	2 ϕ	-	-	-	0.007	0.127	
	3 ϕ	-	-	0.093	-	0.093	
	4 ϕ	-	-	-	-	0.000	
	5 ϕ	-	-	-	-	0.000	
	6 ϕ	-	-	-	-	0.000	
B:可能交通容量	1,067	1,104	1,452	508	524		
A/B:混雑度	0.481	0.369	0.127	0.024	0.422		

交差点交通量

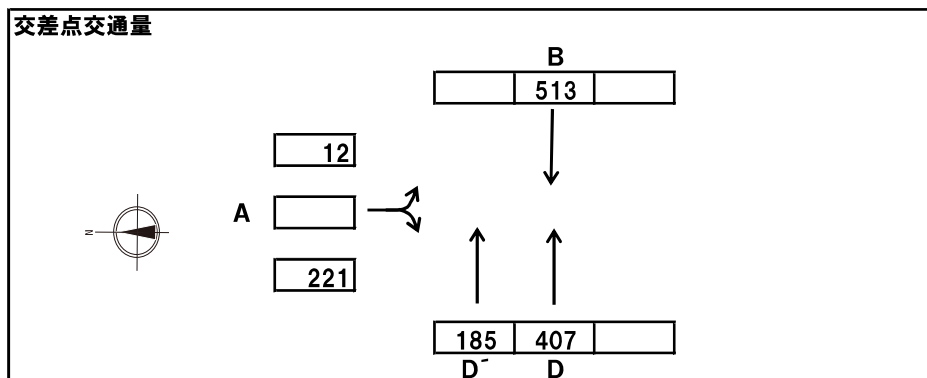

周期	1 ϕ	2 ϕ	3 ϕ	4 ϕ
150	BD青	A青	D'青	
	G 80	G 45	G 110	G

右折⇒信号の変更による通過できる台数

48 台/時・車線

交差点2(自衛隊入口) 休日 現況 14時台

流入部	A			B				C			D			現示の飽和度	交差点飽和度
	左直	右	右矢	左	直	右	右矢	左直	右	右矢	左直	右	右矢		
車線	1	1		1	1	1		1	1		1	1			
車線数	1	1		1	1	1		1	1		1	1			
飽和交通流の基本値 SB	2,000		1,800	1,800	2,000		1,800	2,000		1,800	2,000		1,800		
車線幅員による補正値 αw	0.95		0.95	0.95	0.95		0.95	0.95		0.95	0.95		0.95		
m	2.8		2.6	2.80	2.80		2.6	2.8		2.6	2.9		2.7		
大型車混入による補正値 αT	0.99		1.00	0.97	0.99		0.98	0.99		1.00	0.99		0.98		
%	0.86		0.00	4.79	1.34		2.78	0.56		0.00	1.54		2.78		
左折混入による補正値 αLT	0.99		1.00	0.85	1.00		1.00	0.90		1.00	0.96		1.00		
L%	4.9		-	-	-		-	39.2		-	15.8		-		
有効青時間 G秒	33		-	61	61		-	33		-	61		-		
右折車混入による補正値 αRT	1.00	0.54	1.00	1.00	1.00	0.43	1.00	1.00	0.42	1.00	1.00	0.32	1.00		
R%	-		-	-	-		-	-		-	-		-		
(右折率)															
(有効青時間) G秒	-	33	10	-	-	61	10	-	33	10	-	61	10		
(現示のさばけ台数) (台/C)	-		(48)	-	-		(36)	-		(48)	-		(48)		
飽和交通流率 SA	1,862	923	1,710	1,410	1,881	721	1,676	1,693	718	1,710	1,806	536	1,676		
A:交通量 q	245	0	26	146	447	0	0	293	0	51	462	0	96		
正規化交通量 ρ	0.132	0.000	0.015	0.104	0.238	0.000	0.000	0.173	0.000	0.030	0.256	0.000	0.057		
必要現示率	1φ	0.132	0.000					0.173	0.000					0.173	
	2φ									0.030				0.030	
	3φ			0.104	0.238	0.000					0.256	0.000		0.256	
	4φ						0.000						0.057	0.057	
	5φ													0.000	
	6φ													0.000	
B:可能交通容量	410	203	162	573	765	293	160	372	158	162	734	218	160		
A/B:混雑度	0.598		0.203	0.255	0.584		0.079	0.788		0.309	0.629		0.381		

交差点交通量

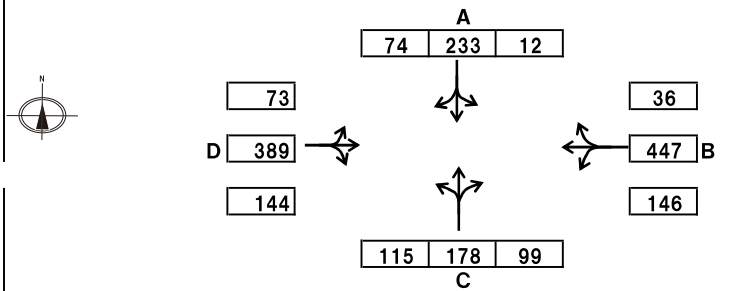

周期	1φ	2φ	3φ	4φ
150	AC青	AC青矢	BD青	BD青矢
G	33	G 10	G 61	G 10
WG	27		WG 56	

右折⇒信号の変更による通過できる台数

48 台/時・車線

交差点2(自衛隊入口) 休日 施設完成後 14時台

流入部	A			B				C			D			現示の飽和度	交差点飽和度
	左直	右	右矢	左	直	右	右矢	左直	右	右矢	左直	右	右矢		
車線	1	1		1	1	1		1	1		1	1			
車線数	1	1		1	1	1		1	1		1	1			
飽和交通流の基本値 SB	2,000		1,800	1,800	2,000		1,800	2,000		1,800	2,000		1,800		
車線幅員による補正値 αw	0.95		0.95	0.95	0.95		0.95	0.95		0.95	0.95		0.95		
m	2.8		2.6	2.80	2.80		2.6	2.8		2.6	2.9		2.7		
大型車混入による補正値 αT	0.99		1.00	0.97	0.99		0.98	0.99		1.00	0.99		0.98		
%	0.86		0.00	4.79	1.34		2.78	0.56		0.00	1.54		2.78		
左折混入による補正値 αLT	0.98		1.00	0.85	1.00		1.00	0.90		1.00	0.96		1.00		
L%	6.8		-	-	-		-	44.4		-	15.8		-		
有効青時間 G秒	33		-	61	61		-	33		-	61		-		
右折車混入による補正値 αRT	1.00	0.54	1.00	1.00	1.00	0.43	1.00	1.00	0.36	1.00	1.00	0.32	1.00		
R%	-	-	-	-	-	-	-	-	-	-	-	-	-		
(右折率)	-	33	10	-	-	61	10	-	33	10	-	61	10		
(有効青時間)	G秒														
(現示のさばけ台数) (台/C)	-		(48)	-	-		(36)	-		(48)	-		(48)		
飽和交通流率 SA	1,843	923	1,710	1,410	1,881	721	1,676	1,693	616	1,710	1,806	536	1,676		
A:交通量 q	279	0	68	146	454	0	0	320	0	51	462	0	96		
正規化交通量 ρ	0.151	0.000	0.040	0.104	0.241	0.000	0.000	0.189	0.000	0.030	0.256	0.000	0.057		
必要現示率	1φ	0.151	0.000					0.189	0.000					0.189	0.542
	2φ			0.040						0.030				0.040	
	3φ				0.104	0.241	0.000					0.256	0.000	0.256	
	4φ						0.000						0.057	0.057	
	5φ													0.000	
	6φ													0.000	
B:可能交通容量	405	203	162	573	765	293	160	372	136	162	734	218	160		
A/B:混雑度	0.689		0.318	0.255	0.593		0.079	0.860		0.332	0.629		0.381		

交差点交通量

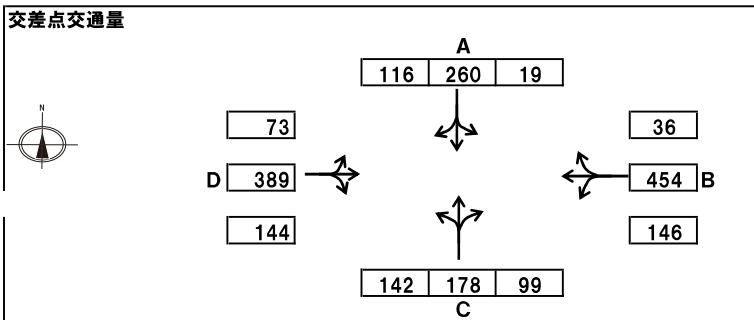

周期	1φ	2φ	3φ	4φ
150	AC青	AC青矢	BD青	BD青矢
G	33	G 10	G 61	G 10
WG	27		WG 56	

右折⇒信号の変更による通過できる台数

48 台/時・車線

交差点3 東方 休日 現況 11時台

流入部		A				B			C				D				
車線		左直	直	右	右矢	左直	右	右矢	左直	直	右	右矢	左直	右	右矢		
車線数		1	1	1		1	1		1	1	1		1	1			
飽和交通流の基本値	S B	2,000	2,000		1,800	2,000		1,800	2,000	2,000		1,800	2,000		1,800		
車線幅員による補正值	α_w	0.95	0.95		0.95	0.95		0.95	0.95	0.95		0.95	0.95		0.95		
	m	2.9	2.9		2.6	2.8		2.6	2.8	2.8		2.6	2.8		2.7		
大型車混入による補正值	α_T	0.97	0.99		0.98	0.99		1.00	0.99	0.99		0.99	0.99		0.99		
	%	4.00	1.52		2.63	2.00		0.00	1.83	1.83		0.76	0.24		2.13		
左折混入による補正值	α_{LT}	0.94	1.00		1.00	0.95		1.00	0.92	1.00		1.00	0.98		1.00		
	L %	20.2	—		—	18.5		—	26.8	—		—	7.2		—		
有効青時間	G秒	37	—		—	46		—	37	—		—	46		—		
右折車混入による補正值	α_{RT}	1.00	1.00	0.48	1.00	1.00	0.32	1.00	1.00	1.00	0.46	1.00	1.00	0.29	1.00		
(右折率)	R %	—	—		—	—		—	—	—		—	—		—		
(有効青時間)	G秒	—	—	37	11	—	46	12	—	—	37	11	—	46	12		
(現示のさげ台数) (台/C)		—	—	—	(76)	—	—	(36)	—	—	—	(80)	—	—	(80)		
飽和交通流率	SA	1.732	1.881	804	1.676	1.787	547	1.710	1.731	1.881	779	1.693	1.843	491	1.693		
A: 交通量	q		446	0	0	540	0	0		453	0	184	447	0	14	現示の飽和度	交差点飽和度
正規化交通量	ρ		0.123	0.000	0.000	0.302	0.000	0.000		0.125	0.000	0.109	0.243	0.000	0.008	0.125	0.544
必要現示率	1 ϕ		0.123	0.000						0.125	0.000					0.125	
	2 ϕ				0.000							0.109				0.109	
	3 ϕ					0.302	0.000						0.243	0.000		0.302	
	4 ϕ							0.000							0.008	0.008	
	5 ϕ															0.000	
	6 ϕ															0.000	
B: 可能交通容量		990	220	217	609	186	232	990	214	218	628	167	230				
A/B: 混雑度		0.451		0.174	0.887		0.086	0.458		0.611	0.712		0.237				

交差点交通量

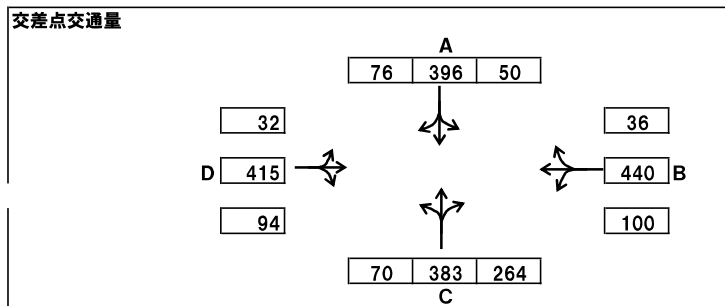

周期	1 ϕ	2 ϕ	3 ϕ	4 ϕ
135	A C 青	A C 青矢	B D 青	B D 青矢
G	37	11	46	12

右折⇒信号の変更による通過できる台数

80 台/時・車線

交差点3 東方 休日 施設完成後 11時台

流入部		A				B			C				D				
車線		左直	直	右	右矢	左直	右	右矢	左直	直	右	右矢	左直	右	右矢		
車線数		1	1	1		1	1		1	1	1		1	1			
飽和交通流の基本値	S B	2,000	2,000		1,800	2,000		1,800	2,000	2,000		1,800	2,000		1,800		
車線幅員による補正値	α_w	0.95	0.95		0.95	0.95		0.95	0.95	0.95		0.95	0.95		0.95		
	m	2.9	2.9		2.6	2.8		2.6	2.8	2.8		2.6	2.8		2.7		
大型車混入による補正値	α_T	0.97	0.99		0.98	0.99		1.00	0.99	0.99		0.99	0.99		0.99		
	%	4.00	1.52		2.63	2.00		0.00	1.83	1.83		0.76	0.24		2.13		
左折混入による補正値	α_{LT}	0.94	1.00		1.00	0.94		1.00	0.92	1.00		1.00	0.98		1.00		
	L %	20.2	—		—	19.7		—	26.3	—		—	8.8		—		
有効青時間	G秒	37	—		—	46		—	37	—		—	46		—		
右折車混入による補正値	α_{RT}	1.00	1.00	0.47	1.00	1.00	0.32	1.00	1.00	1.00	0.46	1.00	1.00	0.28	1.00		
(右折率)	R %	—	—			—			—	—			—				
(有効青時間)	G秒	—	—	37	11	—	46	12	—	—	37	11	—	46	12		
(現示のさげ台数) (台/C)		—	—	—	(76)	—	—	(80)	—	—	—	(80)	—	—	(80)		
飽和交通流率	SA	1.732	1.881	788	1.676	1.768	547	1.710	1.731	1.881	779	1.693	1.843	474	1.693		
A:交通量	q	446	0	0	558	14	0		463	0	184		455	0	14	現示の飽和度	交差点飽和度
正規化交通量	ρ	0.123	0.000	0.000	0.316	0.026	0.000		0.128	0.000	0.109		0.247	0.000	0.008	0.128	0.561
必要現示率	1 ϕ	0.123	0.000						0.128	0.000						0.128	
	2 ϕ			0.000							0.109					0.109	
	3 ϕ				0.316	0.026							0.247	0.000		0.316	
	4 ϕ						0.000								0.008	0.008	
	5 ϕ															0.000	
	6 ϕ															0.000	
B:可能交通容量		990	216	217	602	186	232		990	214	218		628	162	230		
A/B:混雑度		0.451		0.176	0.927		0.225		0.468		0.611		0.725		0.240		

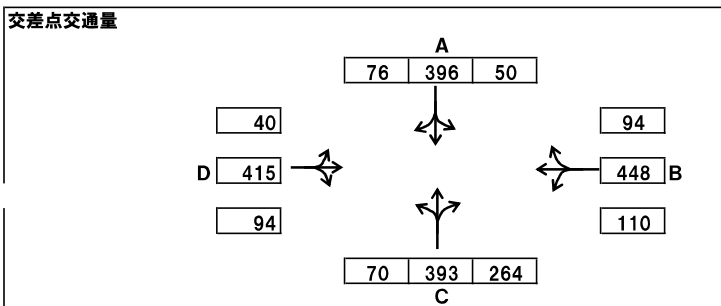

周期	1 ϕ	2 ϕ	3 ϕ	4 ϕ
135	A C 青	A C 青矢	B D 青	B D 青矢
G	37	G 11	G 46	G 12

右折⇒信号の変更による通過できる台数

80 台/時・車線

交差点4（東方2丁目）休日現況 ピーク時16時

流入部		A			B	C			D		
車線		左直	直	右	左直右	左直	直	右	左直右		
車線数		1	1	1	1	1	1	1	1		
飽和交通流の基本値	S B	2,000	2,000	1,800	2,000	2,000	2,000	1,800	2,000		
車線幅員による補正值	α_w	1.00	1.00	1.00	0.95	1.00	1.00	1.00	0.95		
	m	3.0	3.0	2.9	2.8	3.0	3.0	2.9	2.8		
大型車混入による補正值	α_T	0.98	0.98	1.00	0.99	0.99	0.99	1.00	0.98		
	%	3.41	2.58	0.00	1.59	1.17	1.17	0.00	2.63		
左折混入による補正值	α_{LT}	0.92	1.00	1.00	0.94	0.96	1.00	1.00	0.94		
	L %	27.4			22.1	13.8	0.0		22.1		
有効青時間	G秒	35	35		28	35	35		28		
右折車混入による補正值	α_{RT}	1.00	1.00	0.43	0.94	1.00	1.00	0.46	0.91		
(右折率)	R %				16.0				18.0		
(有効青時間)	G秒			35	28			35	28		
(現示のさげ台数) (台/C)											
飽和交通流率	SA	1,803	1,960	775	1,662	1,901	1,980	829	1,593		
A: 交通量	q	554	90		393	555	70		344	現示の	交差点
正規化交通量	ρ	0.147	0.116		0.236	0.143	0.084		0.216	飽和度	飽和度
必要現示率	1 ϕ	0.147	0.116			0.143	0.084			0.147	0.383
	2 ϕ				0.236				0.216	0.236	
	3 ϕ									0.000	
	4 ϕ									0.000	
	5 ϕ									0.000	
	6 ϕ									0.000	
B: 可能交通容量		1,317	271		465	1,358	290		446		
A/B: 混雑度		0.421	0.332		0.845	0.409	0.241		0.771		

交差点交通量

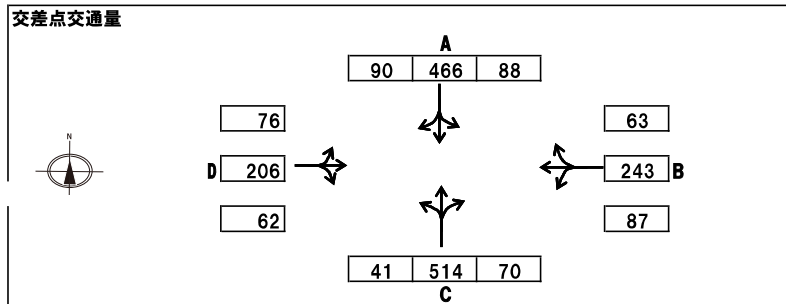

周期	2 ϕ	1 ϕ		
100	BD青	AC青		
	G 28	G 35		

右折⇒信号の変更による通過できる台数 108 台/時・車線

交差点4（東方2丁目）休日施設完成後 ピーク時16時

流入部		A			B	C			D		
車線		左直	直	右	左直右	左直	直	右	左直右		
車線数		1	1	1	1	1	1	1	1		
飽和交通流の基本値	S B	2,000	2,000	1,800	2,000	2,000	2,000	1,800	2,000		
車線幅員による補正值	α_w	1.00	1.00	1.00	0.95	1.00	1.00	1.00	0.95		
	m	3.0	3.0	2.9	2.8	3.0	3.0	2.9	2.8		
大型車混入による補正值	α_T	0.98	0.98	1.00	0.99	0.99	0.99	1.00	0.98		
	%	3.41	2.58	0.00	1.59	1.17	1.17	0.00	2.63		
左折混入による補正值	α_{LT}	0.92	1.00	1.00	0.94	0.96	1.00	1.00	0.94		
	L %	27.4		—	22.1	13.8	0.0	—	22.1		
有効青時間	G秒	35	35	—	28	35	35	—	28		
右折車混入による補正值	α_{RT}	1.00	1.00	0.43	0.94	1.00	1.00	0.46	0.91		
(右折率)	R %	—	—	—	16.0	—	—	—	18.0		
(有効青時間)	G秒	—	—	35	28	—	—	35	28		
(現示のさげ台数) (台/C)		—	—	—	—	—	—	—	—		
飽和交通流率	SA	1,803	1,960	775	1,662	1,901	1,980	829	1,593		
A: 交通量	q	554	90		393	555	146		344	現示の	交差点
正規化交通量	ρ	0.147	0.116		0.236	0.143	0.176		0.216	飽和度	飽和度
必要現示率	1 ϕ	0.147	0.116			0.143	0.176			0.176	0.412
	2 ϕ				0.236					0.216	
	3 ϕ									0.000	
	4 ϕ									0.000	
	5 ϕ									0.000	
	6 ϕ									0.000	
B: 可能交通容量		1,317	271		465	1,358	290		446		
A/B: 混雑度		0.421	0.332		0.845	0.409	0.503		0.771		

交差点交通量

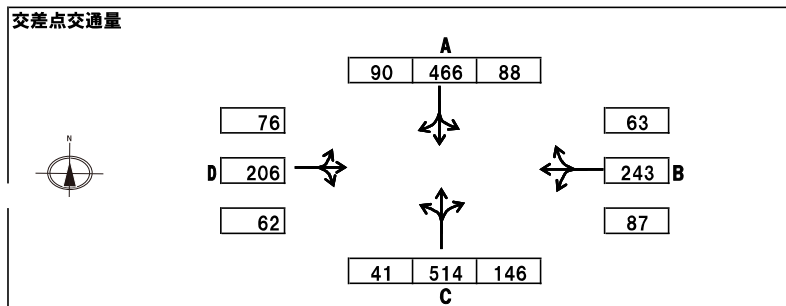

周期	2 ϕ	1 ϕ		
100	BD青	AC青		
	G 28	G 35		

右折⇒信号の変更による通過できる台数

108 台/時・車線

交差点5（新堀北）休日現況 ピーク時15時

流入部	A			B	C			D		
	左直	直	右	左直右	左直	直	右	左直右		
車線	1	0	1	1	1	0	1	1		
車線数	1	0	1	1	1	0	1	1		
飽和交通流の基本値 S B	2,000		1,800	2,000	2,000		1,800	2,000		
車線幅員による補正值 α_w	1.00		1.00	0.95	1.00		1.00	0.95		
m	3.0		2.9	2.8	3.0		2.9	2.8		
大型車混入による補正值 α_T	0.97		0.99	1.00	0.97		0.96	0.99		
%	4.55		1.10	0.90	4.35		5.88	2.35		
左折混入による補正值 α_{LT}	0.98		1.00	0.97	0.93		1.00	0.95		
L %	8.3		-	11.5	24.6		-	17.5		
有効青時間 G秒	25		-	30	25		-	30		
右折車混入による補正值 α_{RT}	1.00		0.59	0.96	1.00		0.54	0.94		
(右折率) R %	-		-	10.5	-		-	18.0		
(有効青時間) G秒	-		25	30	-		25	30		
(現示のさげ台数) (台/C)	-		-	-	-		-	-		
飽和交通流率 SA	1,901		1,056	1,769	1,804		934	1,680		
A: 交通量 q	264	91		286	281	34		395	現示の飽和度	交差点飽和度
正規化交通量 ρ	0.139	0.086		0.162	0.156	0.036		0.235	0.156	0.391
必要現示率	1 ϕ	0.139	0.086		0.156	0.036			0.235	
	2 ϕ			0.162					0.000	
	3 ϕ								0.000	
	4 ϕ								0.000	
	5 ϕ								0.000	
	6 ϕ								0.000	
B: 可能交通容量	594	330		663	564	292		630		
A/B: 混雑度	0.444	0.276		0.431	0.498	0.116		0.627		

交差点交通量

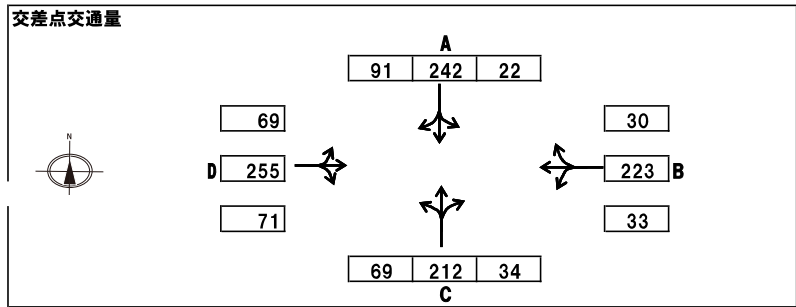

周期	2 ϕ	1 ϕ		
80	BD青	AC青		
	G 30	G 25		

右折⇒信号の変更による通過できる台数 135 台/時・車線

交差点5（新堀北）休日施設完成後 ピーク時15時

流入部		A			B	C			D		
車線		左直	直	右	左直右	左直	直	右	左直右		
車線数		1	0	1	1	1	0	1	1		
飽和交通流の基本値	S B	2,000		1,800	2,000	2,000		1,800	2,000		
車線幅員による補正値	α_w	1.00		1.00	0.95	1.00		1.00	0.95		
	m	3.0		2.9	2.8	3.0		2.9	2.8		
大型車混入による補正値	α_T	0.97		0.99	1.00	0.97		0.96	0.99		
	%	4.55		1.10	0.90	4.35		5.88	2.35		
左折混入による補正値	α_{LT}	0.98		1.00	0.96	0.93		1.00	0.96		
	L %	8.1		—	14.5	24.6		—	15.9		
有効青時間	G秒	25		—	30	25		—	30		
右折車混入による補正値	α_{RT}	1.00		0.59	0.96	1.00		0.53	0.92		
(右折率)	R %	—		—	10.1	—		—	27.8		
(有効青時間)	G秒	—		25	30	—		25	30		
(現示のさげ台数) (台/C)		—		—	—	—		—	—		
飽和交通流率	SA	1,901		1,056	1,751	1,804		916	1,661		
A: 交通量	q	270		91	296	281		34	471	現示の	交差点
正規化交通量	ρ	0.142		0.086	0.169	0.156		0.037	0.284	飽和度	飽和度
必要現示率	1 ϕ	0.142		0.086		0.156		0.037		0.156	0.440
	2 ϕ				0.169				0.284	0.284	
	3 ϕ									0.000	
	4 ϕ									0.000	
	5 ϕ									0.000	
	6 ϕ									0.000	
B: 可能交通容量		594		330	657	564		286	623		
A/B: 混雑度		0.455		0.276	0.451	0.498		0.119	0.756		

交差点交通量

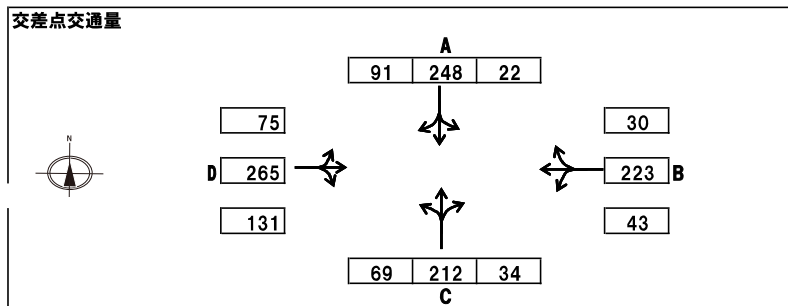

周期	2 ϕ	1 ϕ		
80	BD青	AC青		
	G 30	G 25		

右折⇒信号の変更による通過できる台数

135 台/時・車線

交差点1(久保島) 平日 現況 8時台

流入部	B	D	D'	A			
車線	直	直	直	左	右		
車線数	1	1	1	1	1		
飽和交通流の基本値 S B	2,000	2,000	2,000	1,800	1,800		
車線幅員による補正值 α_w	1.00	1.00	1.00	1.00	1.00		
m	3.3	3.0	3.0	3.0	3.0		
大型車混入による補正值 α_T	0.94	0.96	0.88	0.79	0.87		
%	9.28	5.77	18.82	38.46	21.67		
左折混入による補正值 α_{LT}	1.00	1.00	1.00	1.00	1.00		
L %	-	-	-	100.0	-		
有効青時間 G秒	80	80	110	45	-		
右折車混入による補正值 α_{RT}	1.00	1.00	1.00	1.00	1.00		
(右折率) R %	-	-	-	-	100.0		
(有効青時間) G秒	80	80	110	-	45		
(現示のさげ台数) <台/C	-	-	-	-	-		
飽和交通流率 SA	1.880	1.920	1.760	1.422	1.566		
A : 交通量 q	345	416	340	13	420	現示の飽和度	交差点飽和度
正規化交通量 ρ	0.184	0.217	0.193	0.009	0.268		
必要現示率	1 ϕ	0.184	0.217			0.217	0.678
	2 ϕ				0.009	0.268	
	3 ϕ			0.193		0.193	
	4 ϕ					0.000	
	5 ϕ					0.000	
	6 ϕ					0.000	
B:可能交通容量	1,003	1,072	1,291	427	470		
A/B:混雑度	0.344	0.388	0.263	0.030	0.894		

交差点交通量

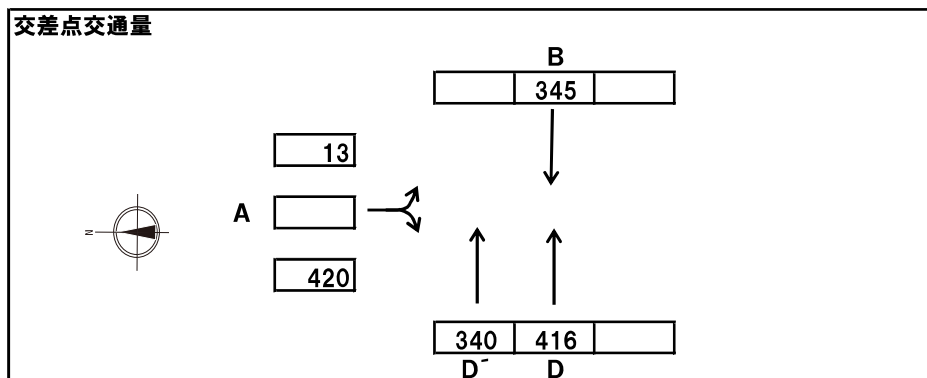

周期	1 ϕ	2 ϕ	3 ϕ	4 ϕ
150	BD青	A青	D'青	
	G 80	G 45	G 110	G

右折⇒信号の変更による通過できる台数

48 台/時・車線

交差点1(久保島) 平日 施設完成後 8時台

流入部	B	D	D'	A			
車線	直	直	直	左	右		
車線数	1	1	1	1	1		
飽和交通流の基本値 SB	2,000	2,000	2,000	1,800	1,800		
車線幅員による補正值 α_w	1.00	1.00	1.00	1.00	1.00		
	m	3.3	3.0	3.0	3.0		
大型車混入による補正值 α_T	0.94	0.96	0.88	0.79	0.87		
	%	9.28	5.77	18.82	38.46	21.67	
左折混入による補正值 α_{LT}	1.00	1.00	1.00	1.00	1.00		
	L %	-	-	-	100.0	-	
有効青時間 G秒	80	80	110	45	-		
右折車混入による補正值 α_{RT}	1.00	1.00	1.00	1.00	1.00		
	(右折率) R %	-	-	-	-	100.0	
(有効青時間) G秒	80	80	110	-	45		
(現示のさげ台数) <台/C	-	-	-	-	-		
飽和交通流率 SA	1.880	1.920	1.760	1.422	1.566		
A : 交通量 q	352	423	340	13	420	現示の飽和度	交差点飽和度
正規化交通量 ρ	0.187	0.220	0.193	0.009	0.268		
必要現示率	1 ϕ	0.187	0.220			0.220	0.681
	2 ϕ				0.009	0.268	
	3 ϕ			0.193		0.193	
	4 ϕ					0.000	
	5 ϕ					0.000	
	6 ϕ					0.000	
B:可能交通容量	1,003	1,072	1,291	427	470		
A/B:混雑度	0.351	0.395	0.263	0.030	0.894		

交差点交通量

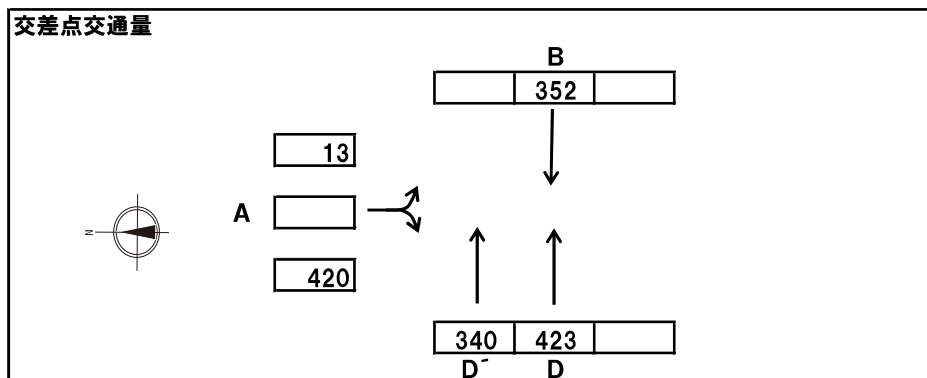

周期	1 ϕ	2 ϕ	3 ϕ	4 ϕ
150	BD青	A青	D'青	
	G 80	G 45	G 110	G

右折⇒信号の変更による通過できる台数

48 台/時・車線

交差点2(自衛隊入口) 平日 現況 14時台

流入部	A			B				C			D			現示の飽和度	交差点飽和度	
	左直	右	右矢	左	直	右	右矢	左直	右	右矢	左直	右	右矢			
車線	1	1		1	1	1		1	1		1	1				
車線数	1	1		1	1	1		1	1		1	1				
飽和交通流の基本値 SB	2,000		1,800	1,800	2,000		1,800	2,000		1,800	2,000		1,800			
車線幅員による補正値 αw	0.95		0.95	0.95	0.95		0.95	0.95		0.95	0.95		0.95			
m	2.8		2.6	2.80	2.80		2.6	2.8		2.6	2.9		2.7			
大型車混入による補正値 αT	0.94		0.95	0.88	0.91		0.96	0.93		0.88	0.92		0.97			
%	9.43		7.14	20.00	13.17		6.25	9.85		26.92	12.63		5.08			
左折混入による補正値 αLT	0.98		1.00	0.85	1.00		1.00	0.94		1.00	0.97		1.00			
L%	3.9		-	-	-		-	25.4		-	13.0		-			
有効青時間 G秒	36		-	64	64		-	36		-	64		-			
右折車混入による補正値 αRT	1.00	0.39	1.00	1.00	1.00	0.44	1.00	1.00	0.33	1.00	1.00	0.39	1.00			
R%	-	-	-	-	-	-	-	-	-	-	-	-	-	-	-	
(有効青時間) G秒	-	36	7	-	-	64	7	-	36	7	-	64	7			
(現示のさげ台数) (台/C)	-		(48)	-	-		(32)	-		(48)	-		(48)			
飽和交通流率 SA	1,750	634	1,625	1,279	1,729	722	1,642	1,661	497	1,505	1,696	647	1,659			
A:交通量 q	309	0	8	160	410	0	0	354	0	108	455	0	70			
正規化交通量 ρ	0.177	0.000	0.005	0.125	0.237	0.000	0.000	0.213	0.000	0.072	0.268	0.000	0.042			
必要現示率	1φ	0.177	0.000					0.213	0.000						0.213	0.595
	2φ			0.005						0.072					0.072	
	3φ				0.125	0.237	0.000					0.268	0.000		0.268	
	4φ						0.000						0.042		0.042	
	5φ														0.000	
	6φ														0.000	
B:可能交通容量	420	152	124	546	738	308	125	399	119	118	724	276	125			
A/B:混雑度	0.736		0.203	0.293	0.556		0.074	0.887		0.658	0.628		0.294			

交差点交通量

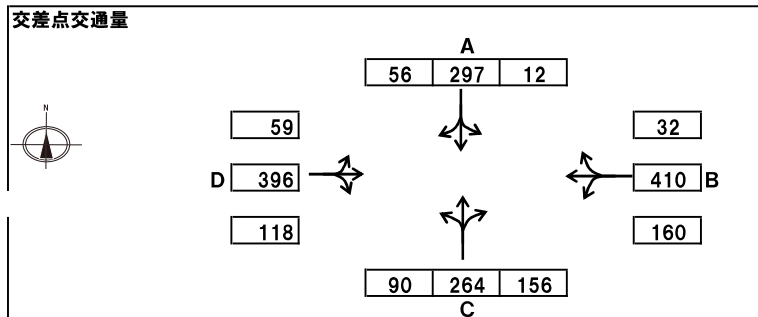

周期	1φ	2φ	3φ	4φ
150	AC青	AC青矢	BD青	BD青矢
	G 36 WG 30	G 7	G 64 WG 59	G 7

右折⇒信号の変更による通過できる台数

48 台/時・車線

交差点2(自衛隊入口) 平日 施設完成後 14時台

流入部	A			B				C			D			現示の飽和度	交差点飽和度
	左直	右	右矢	左	直	右	右矢	左直	右	右矢	左直	右	右矢		
車線	1	1		1	1	1		1	1		1	1			
車線数	1	1		1	1	1		1	1		1	1			
飽和交通流の基本値 SB	2,000		1,800	1,800	2,000		1,800	2,000		1,800	2,000		1,800		
車線幅員による補正値 α _w	0.95		0.95	0.95	0.95		0.95	0.95		0.95	0.95		0.95		
m	2.8		2.6	2.80	2.80		2.6	2.8		2.6	2.9		2.7		
大型車混入による補正値 α _T	0.94		0.95	0.88	0.91		0.96	0.93		0.88	0.92		0.97		
%	9.43		7.14	20.00	13.17		6.25	9.85		26.92	12.63		5.08		
左折混入による補正値 α _L T	0.98		1.00	0.85	1.00		1.00	0.93		1.00	0.97		1.00		
L%	5.5		-	-	-		-	30.7		-	13.0		-		
有効青時間 G秒	36		-	64	64		-	36		-	64		-		
右折車混入による補正値 α _R T	1.00	0.39	1.00	1.00	1.00	0.44	1.00	1.00	0.28	1.00	1.00	0.38	1.00		
R%	-	-	-	-	-	-	-	-	-	-	-	-	-		
(有効青時間) G秒	-	36	7	-	-	64	7	-	36	7	-	64	7		
(現示のさばけ台数) (台/C)	-		(48)	-	-		(32)	-		(48)	-		(48)		
飽和交通流率 SA	1,750	634	1,625	1,279	1,729	722	1,642	1,643	421	1,505	1,696	630	1,659		
A:交通量 q	343	0	50	160	417	0	0	381	0	108	455	0	70		
正規化交通量 ρ	0.196	0.000	0.031	0.125	0.241	0.000	0.000	0.232	0.000	0.072	0.268	0.000	0.042		
必要現示率	1φ	0.196	0.000					0.232	0.000					0.232	
	2φ			0.031						0.072				0.072	
	3φ				0.125	0.241	0.000					0.268	0.000	0.268	
	4φ						0.000						0.042	0.042	
	5φ													0.000	
	6φ													0.000	
B:可能交通容量	420	152	124	546	738	308	125	394	101	118	724	269	125		
A/B:混雑度	0.817		0.355	0.293	0.565		0.074	0.967		0.712	0.628		0.299		

交差点交通量

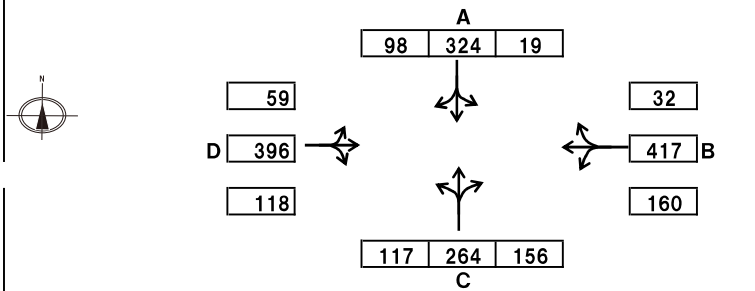

周期	1φ	2φ	3φ	4φ
150	AC青	AC青矢	BD青	BD青矢
G	36	G 7	G 64	G 7
WG	30		WG 59	

右折⇒信号の変更による通過できる台数

48 台/時・車線

交差点3 東方 平日 現況 8時台

流入部		A				B			C				D				
車線		左直	直	右	右矢	左直	右	右矢	左直	直	右	右矢	左直	右	右矢		
車線数		1	1	1		1	1		1	1	1		1	1			
飽和交通流の基本値	S B	2,000	2,000		1,800	2,000		1,800	2,000	2,000		1,800	2,000		1,800		
車線幅員による補正値	α_w	0.95	0.95		0.95	0.95		0.95	0.95	0.95		0.95	0.95		0.95		
	m	2.9	2.9		2.6	2.8		2.6	2.8	2.8		2.6	2.8		2.7		
大型車混入による補正値	α_T	0.92	0.92		0.92	0.99		1.00	0.88	0.88		0.88	0.93		0.93		
	%	10.93	10.93		10.71	22.81		12.50	21.18	21.18		23.49	10.00		10.38		
左折混入による補正値	α_{LT}	0.97	1.00		1.00	0.91		1.00	0.93	1.00		1.00	0.98		1.00		
	L %	9.6	—		—	30.7		—	24.3	—		—	6.5		—		
有効青時間	G秒	37	—		—	46		—	37	—		—	46		—		
右折車混入による補正値	α_{RT}	1.00	1.00	0.38	1.00	1.00	0.50	1.00	1.00	1.00	0.28	1.00	1.00	0.55	1.00		
(右折率)	R %	—	—		—	—		—	—	—		—	—		—		
(有効青時間)	G秒	—	—	37	11	—	46	12	—	—	37	11	—	46	12		
(現示のさげ台数) (台/C)		—	—	—	(84)	—	—	(40)	—	—	—	(80)	—	—	(80)		
飽和交通流率	SA	1,696	1,748	598	1,573	1,712	855	1,710	1,555	1,672	421	1,505	1,732	875	1,590		
A: 交通量	q		636	0	0	371	0	0		570	0	86	307	0	26	現示の飽和度	交差点飽和度
正規化交通量	ρ		0.185	0.000	0.000	0.217	0.000	0.000		0.177	0.000	0.057	0.177	0.000	0.016	0.185	0.475
必要現示率	1 ϕ		0.185	0.000						0.177	0.000					0.185	
	2 ϕ				0.000							0.057				0.057	
	3 ϕ					0.217	0.000						0.177	0.000		0.217	
	4 ϕ							0.000							0.016	0.016	
	5 ϕ															0.000	
	6 ϕ															0.000	
B: 可能交通容量			944	164	208	583	291	232		884	115	203	590	298	221		
A/B: 混雑度			0.674		0.226	0.636		0.076		0.645		0.522	0.520		0.204		

交差点交通量

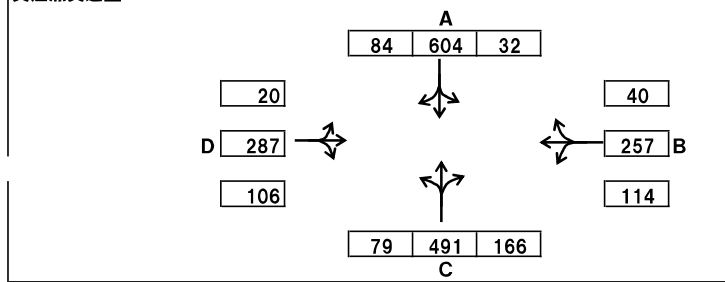

周期	1 ϕ	2 ϕ	3 ϕ	4 ϕ
135	A C 青	A C 青矢	B D 青	B D 青矢
G	37	11	46	12

右折⇒信号の変更による通過できる台数

80 台/時・車線

交差点3 東方 平日 施設完成後 8時台

流入部		A				B			C				D				
車線		左直	直	右	右矢	左直	右	右矢	左直	直	右	右矢	左直	右	右矢		
車線数		1	1	1		1	1		1	1	1		1	1			
飽和交通流の基本値	SB	2,000	2,000		1,800	2,000		1,800	2,000	2,000		1,800	2,000		1,800		
車線幅員による補正值	α_w	0.95	0.95		0.95	0.95		0.95	0.95	0.95		0.95	0.95		0.95		
	m	2.9	2.9		2.6	2.8		2.6	2.8	2.8		2.6	2.8		2.7		
大型車混入による補正值	α_T	0.92	0.92		0.92	0.99		1.00	0.88	0.88		0.88	0.93		0.93		
	%	10.93	10.93		10.71	22.81		12.50	21.18	21.18		23.49	10.00		10.38		
左折混入による補正值	α_{LT}	0.97	1.00		1.00	0.91		1.00	0.93	1.00		1.00	0.98		1.00		
	L%	9.6	—		—	31.9		—	24.0	—		—	8.9		—		
有効青時間	G秒	37	—		—	46		—	37	—		—	46		—		
右折車混入による補正值	α_{RT}	1.00	1.00	0.37	1.00	1.00	0.50	1.00	1.00	1.00	0.28	1.00	1.00	0.53	1.00		
(右折率)	R%	—	—		—	—		—	—	—		—	—		—		
(有効青時間)	G秒	—	—	37	11	—	46	12	—	—	37	11	—	46	12		
(現示のさげ台数) (台/C)		—	—	—	(84)	—	—	(80)	—	—	—	(80)	—	—	(80)		
飽和交通流率	SA	1.696	1.748	582	1,573	1.712	855	1,710	1.555	1.672	421	1,505	1.732	843	1,590		
A:交通量	q	636	0	0		389	18	0	580	0	86		315	0	26	現示の飽和度	交差点飽和度
正規化交通量	ρ	0.185	0.000	0.000		0.227	0.021	0.000	0.180	0.000	0.057		0.182	0.000	0.016	0.185	0.485
必要現示率	1 ϕ	0.185	0.000						0.180	0.000						0.185	
	2 ϕ			0.000							0.057					0.057	
	3 ϕ					0.227	0.021						0.182	0.000		0.227	
	4 ϕ							0.000							0.016	0.016	
	5 ϕ														0.000	0.000	
	6 ϕ														0.000	0.000	
B:可能交通容量		944	160	208		583	291	232	884	115	203		590	287	221		
A/B:混雑度		0.674		0.228		0.667		0.187	0.656		0.522		0.534		0.209		

交差点交通量

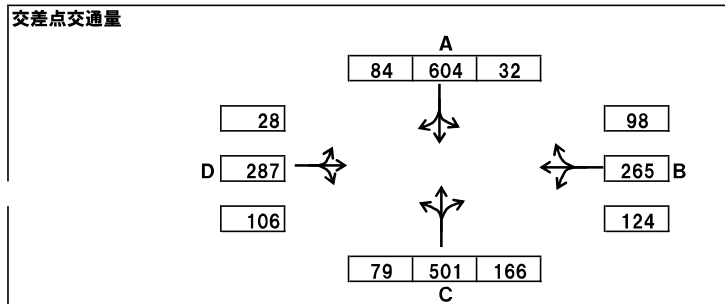

周期	1 ϕ	2 ϕ	3 ϕ	4 ϕ
135	AC青	AC青矢	BD青	BD青矢
G	37	11	46	12

右折⇒信号の変更による通過できる台数

80 台/時・車線

交差点4（東方2丁目）平日現況 ピーク時9時

流入部	A			B	C			D		
	左直	直	右	左直右	左直	直	右	左直右		
車線	1	1	1	1	1	1	1	1		
車線数	1	1	1	1	1	1	1	1		
飽和交通流の基本値 SB	2,000	2,000	1,800	2,000	2,000	2,000	1,800	2,000		
車線幅員による補正值 αw	1.00	1.00	1.00	0.95	1.00	1.00	1.00	0.95		
m	3.0	3.0	2.9	2.8	3.0	3.0	2.9	2.8		
大型車混入による補正值 αT	0.89	0.89	0.99	0.98	0.83	0.83	1.00	0.98		
%	17.34	17.34	1.45	3.75	29.81	29.81	0.95	2.93		
左折混入による補正值 αLT	0.96	1.00	1.00	0.93	0.97	1.00	1.00	0.94		
L%	13.0			25.7	12.3	0.0		19.5		
有効青時間 G秒	35	35		28	35	35		28		
右折車混入による補正值 αRT	1.00	1.00	0.45	0.93	1.00	1.00	0.30	0.96		
(右折率) R%				19.0				14.0		
(有効青時間) G秒			35	28			35	28		
(現示のさげ台数) (台/C)										
飽和交通流率 SA	1,709	1,780	803	1,610	1,610	1,660	537	1,680		
A: 交通量 q		750	69	311		517	105	308	現示の	交差点
正規化交通量 ρ		0.215	0.086	0.193		0.158	0.196	0.183	飽和度	飽和度
必要現示率	1φ	0.215	0.086			0.158	0.196		0.215	0.408
	2φ			0.193				0.183	0.193	
	3φ								0.000	
	4φ								0.000	
	5φ								0.000	
	6φ								0.000	
B: 可能交通容量		1,221	281	451		1,145	188	470		
A/B: 混雑度		0.614	0.246	0.690		0.452	0.559	0.655		

交差点交通量

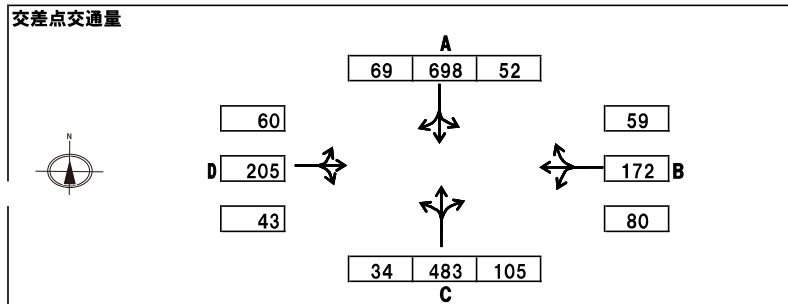

周期	2φ	1φ		
100	BD青	AC青		
	G 28	G 35		

右折⇒信号の変更による通過できる台数 108 台/時・車線

交差点4（東方2丁目）平日施設完成後 ピーク時9時

流入部	A			B	C			D		
	左直	直	右	左直右	左直	直	右	左直右		
車線	1	1	1	1	1	1	1	1		
車線数	1	1	1	1	1	1	1	1		
飽和交通流の基本値 SB	2,000	2,000	1,800	2,000	2,000	2,000	1,800	2,000		
車線幅員による補正值 α_w	1.00	1.00	1.00	0.95	1.00	1.00	1.00	0.95		
m	3.0	3.0	2.9	2.8	3.0	3.0	2.9	2.8		
大型車混入による補正值 α_T	0.89	0.89	0.99	0.98	0.83	0.83	1.00	0.98		
%	17.34	17.34	1.45	3.75	29.81	29.81	0.95	2.93		
左折混入による補正值 α_{LT}	0.96	1.00	1.00	0.93	0.97	1.00	1.00	0.94		
L%	13.0			25.7	12.3	0.0		19.5		
有効青時間 G秒	35	35		28	35	35		28		
右折車混入による補正值 α_{RT}	1.00	1.00	0.45	0.93	1.00	1.00	0.30	0.96		
(右折率) R%				19.0				14.0		
(有効青時間) G秒			35	28			35	28		
(現示のさげ台数) (台/C)										
飽和交通流率 SA	1,709	1,780	803	1,610	1,610	1,660	537	1,680		
A: 交通量 q		750	69	311		517	181	308	現示の飽和度	交差点飽和度
正規化交通量 ρ		0.215	0.086	0.193		0.158	0.337	0.183		
必要現示率	1 ϕ		0.215	0.086		0.158	0.337		0.337	0.530
	2 ϕ				0.193				0.183	
	3 ϕ								0.000	
	4 ϕ								0.000	
	5 ϕ								0.000	
	6 ϕ								0.000	
B: 可能交通容量		1,221	281	451		1,145	188	470		
A/B: 混雑度		0.614	0.246	0.690		0.452	0.963	0.655		

交差点交通量

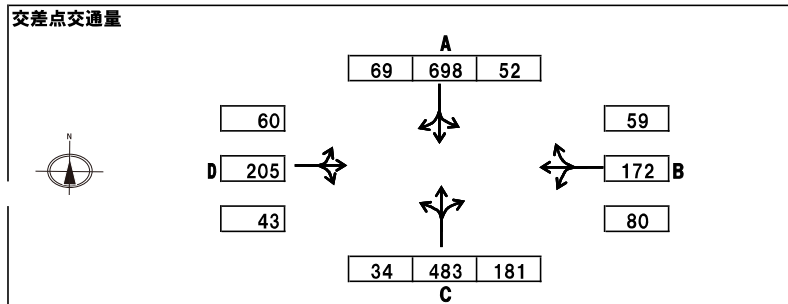

周期	2 ϕ	1 ϕ		
100	BD青	AC青		
	G 28	G 35		

右折⇒信号の変更による通過できる台数 108 台/時・車線

交差点5（新堀北）平日現況 ピーク時8時

流入部		A			B	C			D		
車線		左直	直	右	左直右	左直	直	右	左直右		
車線数		1	0	1	1	1	0	1	1		
飽和交通流の基本値	S B	2,000		1,800	2,000	2,000		1,800	2,000		
車線幅員による補正値	α_w	1.00		1.00	0.95	1.00		1.00	0.95		
	m	3.0		2.9	2.8	3.0		2.9	2.8		
大型車混入による補正値	α_T	0.91		0.97	0.98	0.90		0.92	0.97		
	%	13.73		4.11	2.63	15.82		12.50	4.84		
左折混入による補正値	α_{LT}	0.99		1.00	0.97	0.95		1.00	0.96		
	L %	4.6		—	10.3	16.2		—	14.2		
有効青時間	G秒	25		—	30	25		—	30		
右折車混入による補正値	α_{RT}	1.00		0.42	0.96	1.00		0.24	0.89		
(右折率)	R %	—		—	10.1	—		—	24.0		
(有効青時間)	G秒	—		25	30	—		25	30		
(現示のさげ台数) (台/C)		—		—	—	—		—	—		
飽和交通流率	SA	1,802		736	1,734	1,710		396	1,575		
A: 交通量	q	458		73	378	377		72	438	現示の	交差点
正規化交通量	ρ	0.254		0.099	0.218	0.220		0.182	0.278	飽和度	飽和度
必要現示率	1 ϕ	0.254		0.099		0.220		0.182		0.254	0.532
	2 ϕ				0.218				0.278	0.278	
	3 ϕ									0.000	
	4 ϕ									0.000	
	5 ϕ									0.000	
	6 ϕ									0.000	
B: 可能交通容量		563		230	650	534		124	591		
A/B: 混雑度		0.813		0.317	0.582	0.706		0.581	0.741		

交差点交通量

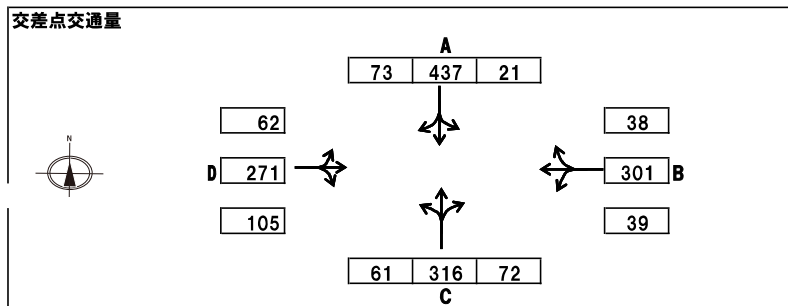

周期	2 ϕ	1 ϕ		
80	BD青	AC青		
	G 30	G 25		

右折⇒信号の変更による通過できる台数

135 台/時・車線

交差点5（新堀北）平日施設完成後 ピーク時8時

流入部	A			B	C			D		
	左直	直	右	左直右	左直	直	右	左直右		
車線数	1	0	1	1	1	0	1	1		
飽和交通流の基本値 SB	2,000		1,800	2,000	2,000		1,800	2,000		
車線幅員による補正値 αw	1.00		1.00	0.95	1.00		1.00	0.95		
m	3.0		2.9	2.8	3.0		2.9	2.8		
大型車混入による補正値 αT	0.91		0.97	0.98	0.90		0.92	0.97		
%	13.73		4.11	2.63	15.82		12.50	4.84		
左折混入による補正値 αLT	0.99		1.00	0.97	0.95		1.00	0.96		
L%	4.5		—	12.6	16.2		—	13.2		
有効青時間 G秒	25		—	30	25		—	30		
右折車混入による補正値 αRT	1.00		0.42	0.95	1.00		0.23	0.85		
(右折率) R%	—		—	9.8	—		—	32.1		
(有効青時間) G秒	—		25	30	—		25	30		
(現示のさげ台数) (台/C)	—		—	—	—		—	—		
飽和交通流率 SA	1,802		736	1,716	1,710		379	1,504		
A: 交通量 q	464	73		388	377	72		514	現示の飽和度	交差点飽和度
正規化交通量 ρ	0.257	0.099		0.226	0.220	0.190		0.342	0.257	0.599
必要現示率	1φ	0.257	0.099		0.220	0.190			0.257	
	2φ							0.342	0.342	
	3φ								0.000	
	4φ								0.000	
	5φ								0.000	
	6φ								0.000	
B: 可能交通容量	563	230		644	534	118		564		
A/B: 混雑度	0.824	0.317		0.602	0.706	0.610		0.911		

交差点交通量

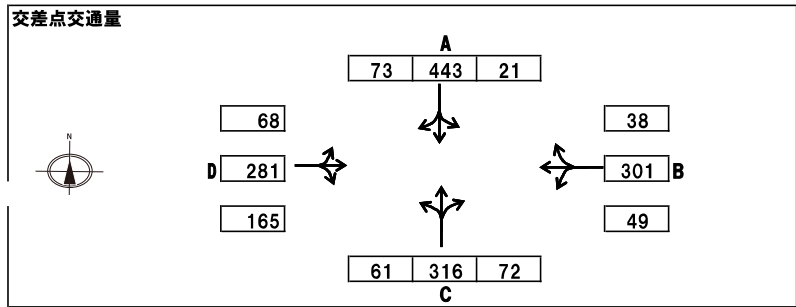

周期	2φ	1φ		
80	BD青	AC青		
	G 30	G 25		

右折⇒信号の変更による通過できる台数

135 台/時・車線

評価（信号交差点車線別混雑度）

信号交差点である交差点1については現況及び計画に伴う発生交通量の最大ピーク台数より車線別混雑度を評価した。
すべての車線について交通容量内に収まる結果となる。

交差点1（車線別混雑度）

	現況					施設完成後				
	流入	車線	交通量	交通容量	混雑度	流入	車線	交通量	交通容量	混雑度
休日車線別混雑度	B	直進	506	1,067	0.474	B	直進	513	1,067	0.481
	D	直進	400	1,104	0.362	D	直進	407	1,104	0.369
	D'	直進	185	1,452	0.127	D'	直進	185	1,452	0.127
	A	左折	12	508	0.024	A	左折	12	508	0.024
		右折	221	524	0.422		右折	221	524	0.422

交差点2

	現況					施設完成後				
	流入	車線	交通量	交通容量	混雑度	流入	車線	交通量	交通容量	混雑度
休日車線別混雑度	A	左直	245	410	0.598	A	左直	279	405	0.689
		右折	74	365	0.203		右折	116	365	0.318
	B	左折	146	573	0.255	B	左折	146	573	0.255
		直進	447	765	0.584		直進	454	765	0.593
		右折	36	453	0.079		右折	36	453	0.079
	C	左直	293	372	0.788	C	左直	320	372	0.86
		右折	99	320	0.309		右折	99	298	0.332
	D	左直	462	734	0.629	D	左直	462	734	0.629
		右折	144	378	0.381		右折	144	378	0.381

交差点3

	現況					施設完成後				
	流入	車線	交通量	交通容量	混雑度	流入	車線	交通量	交通容量	混雑度
休日車線別混雑度	A	左直	446	990	0.451	A	左直	446	990	0.451
		右折	76	437	0.174		右折	76	433	0.176
	B	左直	540	609	0.887	B	左直	558	602	0.927
		右折	36	418	0.086		右折	94	418	0.225
	C	左直	453	990	0.458	C	左直	463	990	0.468
		右折	264	432	0.611		右折	264	432	0.611
	D	左直	447	628	0.712	D	左直	455	628	0.725
		右折	94	397	0.237		右折	94	392	0.24

交差点4

	現況					施設完成後				
	流入	車線	交通量	交通容量	混雑度	流入	車線	交通量	交通容量	混雑度
休日車線別混雑度	A	左直	554	1,317	0.421	A	左直	554	1,317	0.421
		右折	90	271	0.332		右折	90	271	0.332
	B	左直右	393	465	0.845	B	左直右	393	465	0.845
	C	左直	555	1,358	0.409	C	左直	555	1,358	0.409
		右折	70	290	0.241		右折	146	290	0.503
	D	左直右	344	446	0.771	D	左直右	344	446	0.771

交差点5

	現況					施設完成後				
	流入	車線	交通量	交通容量	混雑度	流入	車線	交通量	交通容量	混雑度
休日車線別混雑度	A	左直	264	594	0.444	A	左直	270	594	0.455
		右折	91	330	0.276		右折	91	330	0.276
	B	左直右	286	663	0.431	B	左直右	296	657	0.451
	C	左直	281	564	0.498	C	左直	281	564	0.498
		右折	34	292	0.116		右折	34	286	0.119
	D	左直右	395	630	0.627	D	左直右	471	623	0.756

評価（信号交差点車線別混雑度）

信号交差点である交差点1については現況及び計画に伴う発生交通量の最大ピーク台数より車線別混雑度を評価した。
すべての車線について交通容量内に収まる結果となる。

交差点1（車線別混雑度）

	現況					施設完成後				
	流入	車線	交通量	交通容量	混雑度	流入	車線	交通量	交通容量	混雑度
平日車線別混雑度	B	直進	345	1,003	0.344	B	直進	352	1,003	0.351
	D	直進	416	1,072	0.388	D	直進	423	1,072	0.395
	D'	直進	340	1,291	0.263	D'	直進	340	1,291	0.263
	A	左折	13	427	0.03	A	左折	13	427	0.03
		右折	420	470	0.894		右折	420	470	0.894

交差点2

	現況					施設完成後				
	流入	車線	交通量	交通容量	混雑度	流入	車線	交通量	交通容量	混雑度
平日車線別混雑度	A	左直	309	420	0.736	A	左直	343	420	0.817
		右折	56	276	0.203		右折	98	276	0.355
	B	左折	160	546	0.293	B	左折	160	546	0.293
		直進	410	738	0.556		直進	417	738	0.565
		右折	32	433	0.074		右折	32	433	0.074
	C	左直	354	399	0.887	C	左直	381	394	0.967
		右折	156	237	0.658		右折	156	219	0.712
	D	左直	455	724	0.628	D	左直	455	724	0.628
		右折	118	401	0.294		右折	118	394	0.299

交差点3

	現況					施設完成後				
	流入	車線	交通量	交通容量	混雑度	流入	車線	交通量	交通容量	混雑度
平日車線別混雑度	A	左直	636	944	0.674	A	左直	636	944	0.674
		右折	84	372	0.226		右折	84	368	0.228
	B	左直	371	583	0.636	B	左直	389	583	0.667
		右折	40	523	0.076		右折	98	523	0.187
	C	左直	570	884	0.645	C	左直	580	884	0.656
		右折	166	318	0.522		右折	166	318	0.522
	D	左直	307	590	0.52	D	左直	315	590	0.534
		右折	106	519	0.204		右折	106	508	0.209

交差点4

	現況					施設完成後				
	流入	車線	交通量	交通容量	混雑度	流入	車線	交通量	交通容量	混雑度
平日車線別混雑度	A	左直	750	1,221	0.614	A	左直	750	1,221	0.614
		右折	69	281	0.246		右折	69	281	0.246
	B	左直右	311	451	0.69	B	左直右	311	451	0.69
	C	左直	517	1,145	0.452	C	左直	517	1,145	0.452
		右折	105	188	0.559		右折	181	188	0.963
	D	左直右	308	470	0.655	D	左直右	308	470	0.655

交差点5

	現況					施設完成後				
	流入	車線	交通量	交通容量	混雑度	流入	車線	交通量	交通容量	混雑度
平日車線別混雑度	A	左直	458	563	0.813	A	左直	464	563	0.824
		右折	73	230	0.317		右折	73	230	0.317
	B	左直右	378	650	0.582	B	左直右	388	644	0.602
	C	左直	377	534	0.706	C	左直	377	534	0.706
		右折	72	124	0.581		右折	72	118	0.61
	D	左直右	438	591	0.741	D	左直右	514	564	0.91